



PROFILE COLLECTION

www.chinasmartech.com

绍兴仕马特机械制造有限公司
SHAOXING SMARTECH MACHINERY MANUFACTURING CO., LTD.

Address: Lanting, Shaoxing, ZheJiang, China

Tel: 0086-575-81162787

Fax: 0086-575-84315666

Mail: smartech@chinasmartech.com

[Http://www.chinasmartech.com](http://www.chinasmartech.com)

[Http://www.smtformingmachine.com](http://www.smtformingmachine.com)



绍兴仕马特机械制造有限公司
SHAOXING SMARTECH MACHINERY MANUFACTURING CO., LTD.

立体效果图
Stereo view

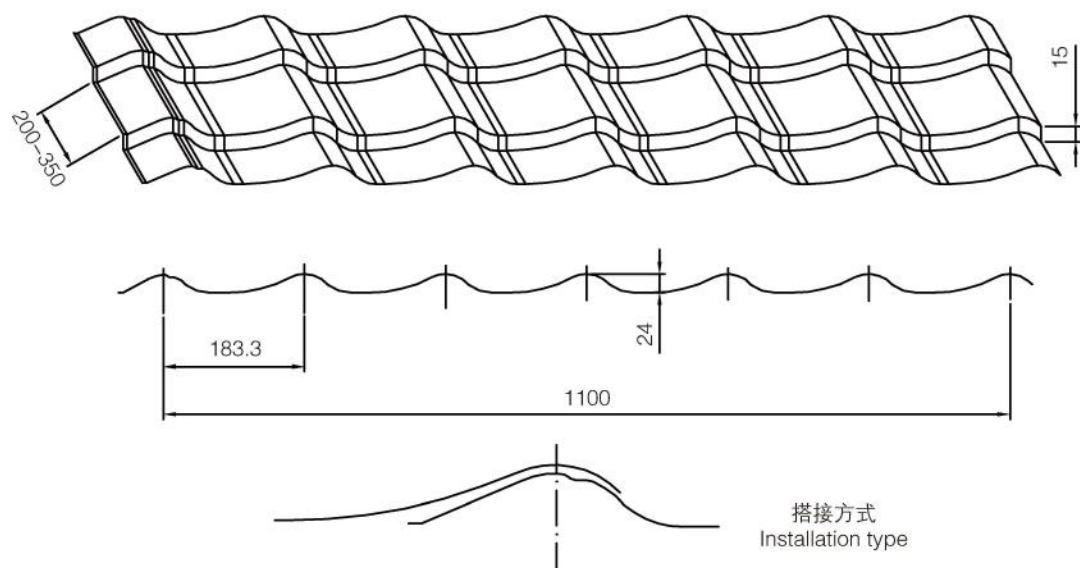

型号 Model	有效覆盖宽度 (mm) Cover width	展开宽度 (mm) Coil width	板厚 (mm) Thickness
YLD183	1100	1250	0.4
			0.6

立体效果图
Stereo view

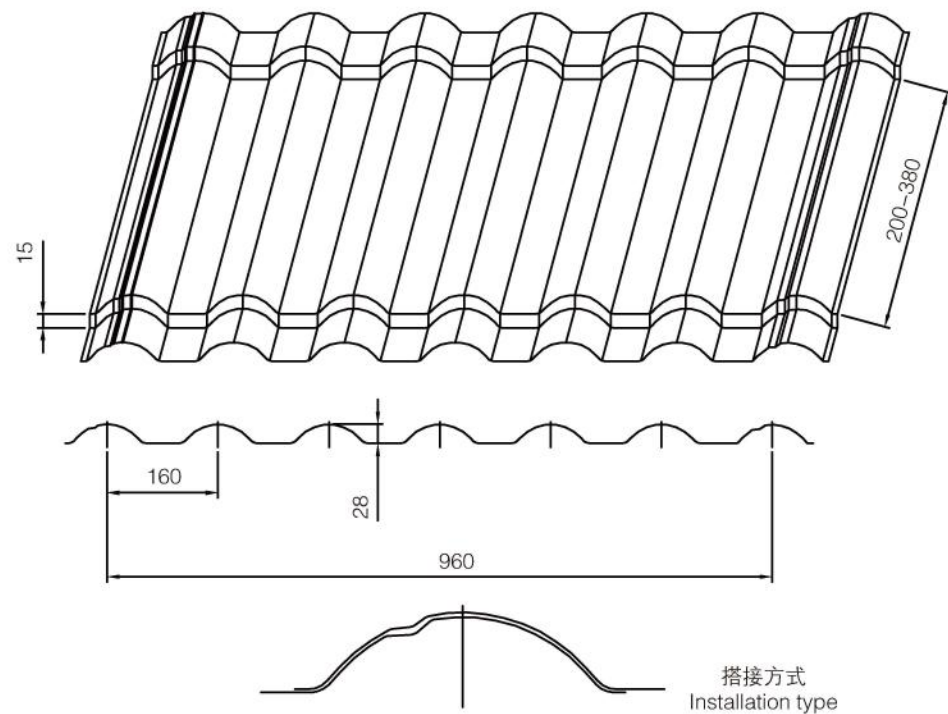

型号 Model	有效覆盖宽度 (mm) Cover width	展开宽度 (mm) Coil width	板厚 (mm) Thickness
YLA160	960	1200	0.4
			0.6

立体效果图
Stereo view

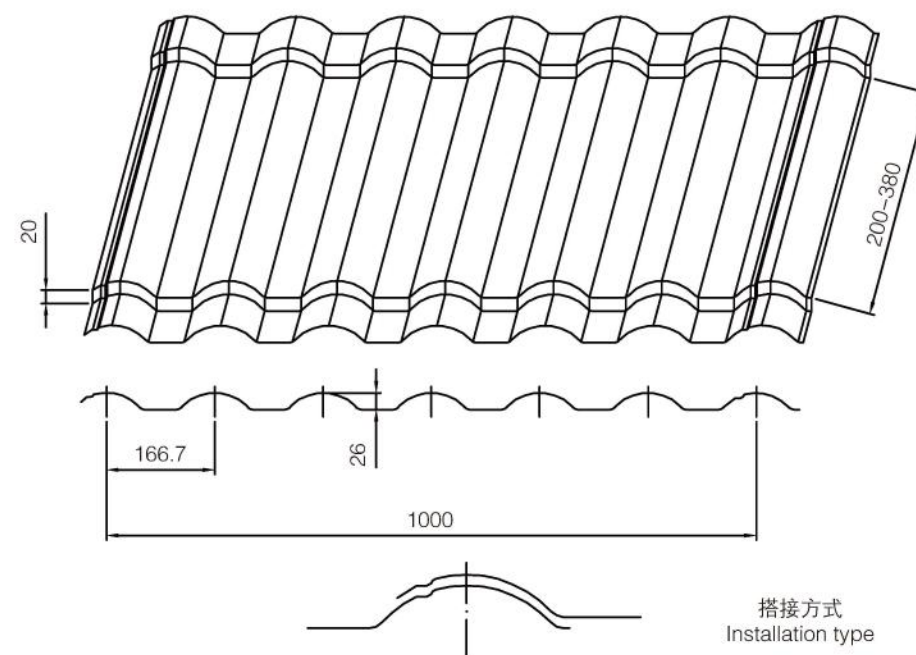

型号 Model	有效覆盖宽度 (mm) Cover width	展开宽度 (mm) Coil width	板厚 (mm) Thickness
YLA167	1000	1250	0.4
			0.6

立体效果图
Stereo view

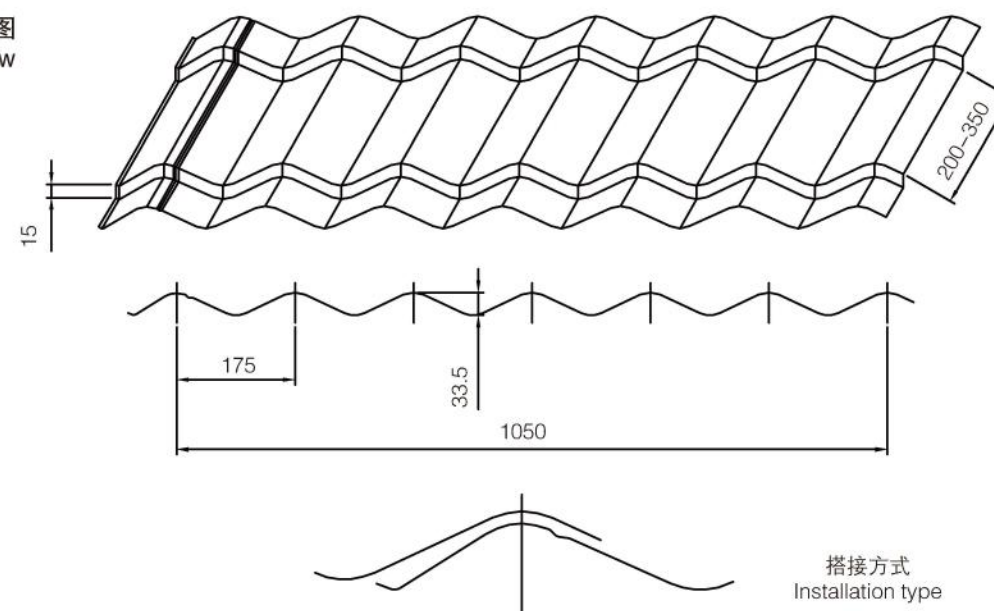

型号 Model	有效覆盖宽度 (mm) Cover width	展开宽度 (mm) Coil width	板厚 (mm) Thickness
YLA175	1050	1250	0.4
			0.7

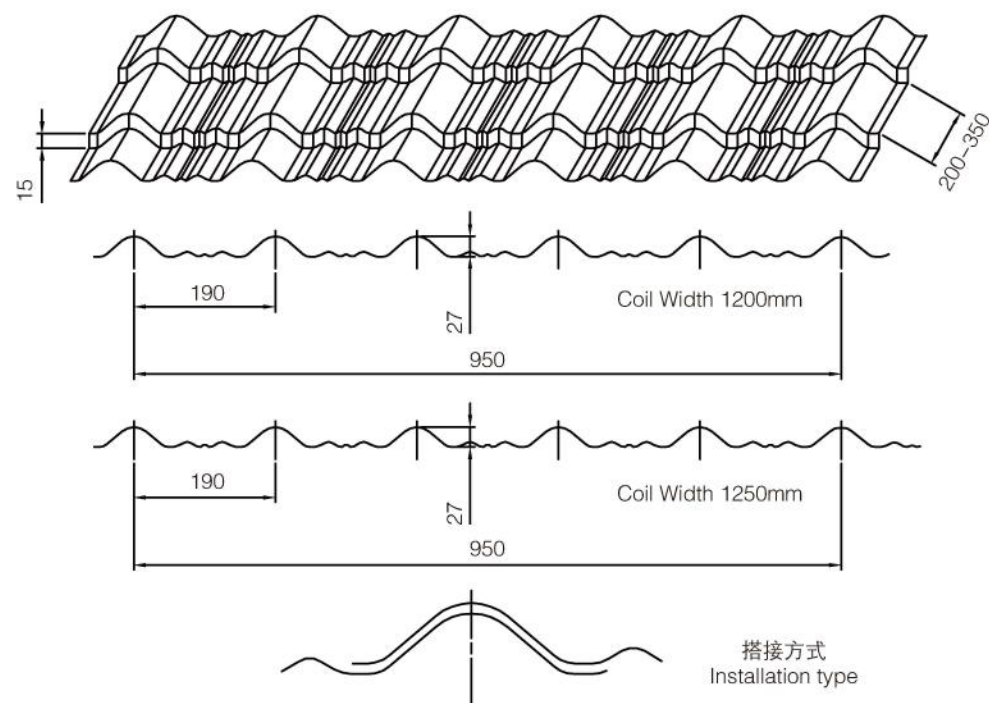
立体效果图
 Stereo view

型号 Model	有效覆盖宽度 (mm) Cover width	展开宽度 (mm) Coil width	板厚 (mm) Thickness
YLC190A	950	1200-1250	0.4
			0.6

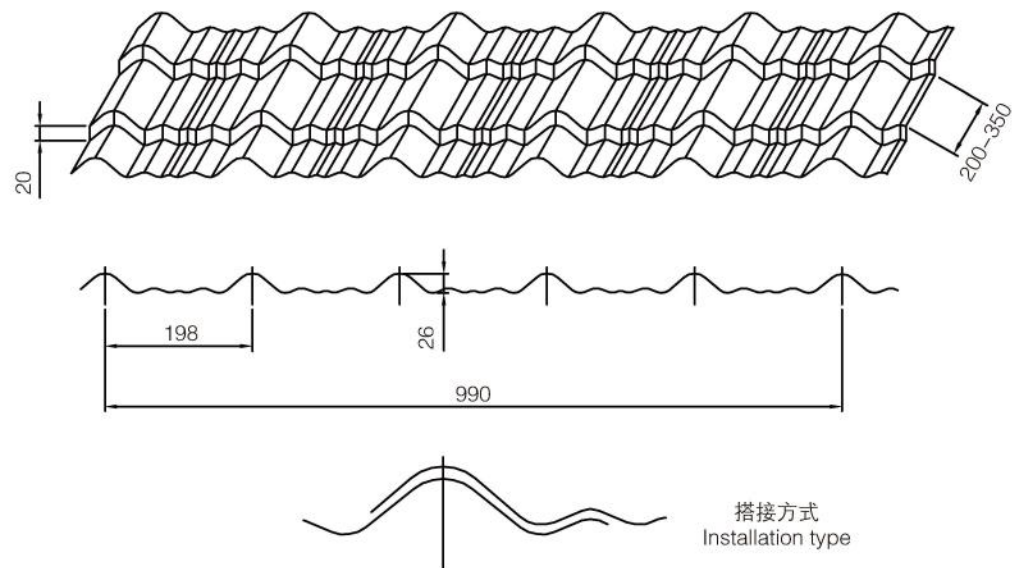
 立体效果图
 Stereo view

型号 Model	有效覆盖宽度 (mm) Cover width	展开宽度 (mm) Coil width	板厚 (mm) Thickness
YLA198	990	1220	0.4
			0.6

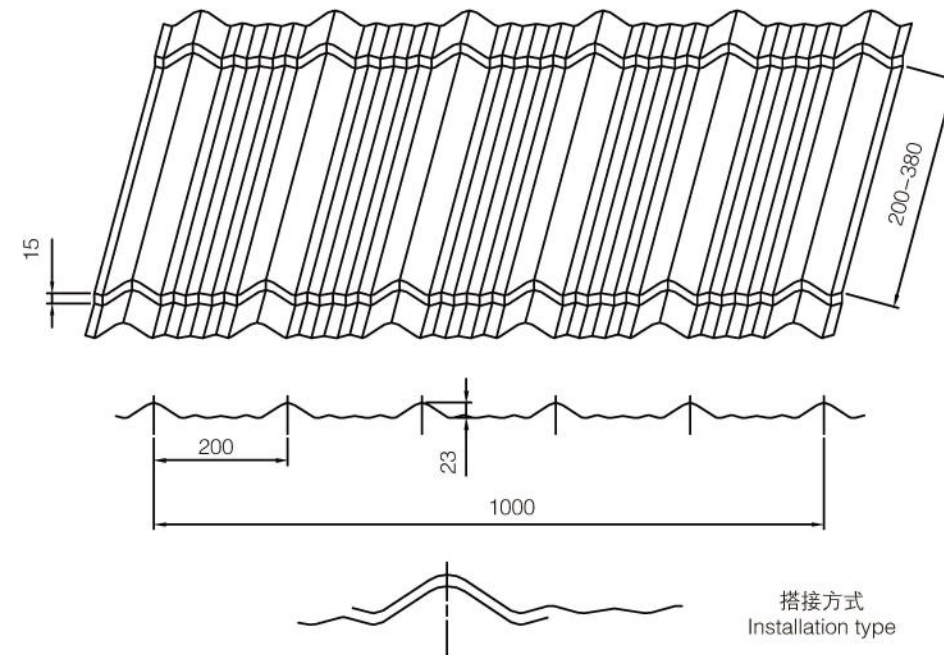
 立体效果图
 Stereo view

型号 Model	有效覆盖宽度 (mm) Cover width	展开宽度 (mm) Coil width	板厚 (mm) Thickness
YLA200	1000	1200	0.3
			0.7

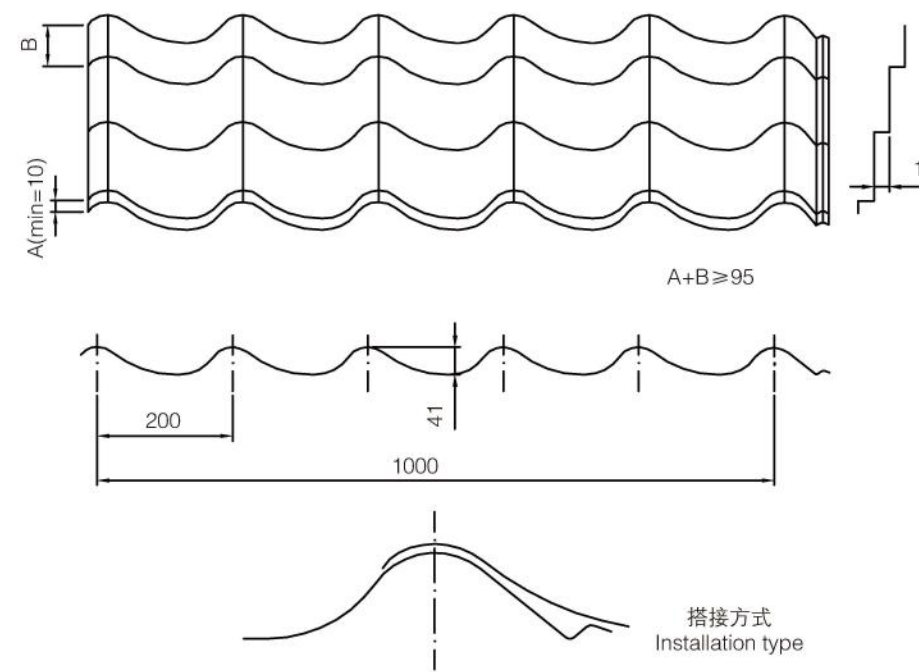
 立体效果图
 Stereo view

型号 Model	有效覆盖宽度 (mm) Cover width	展开宽度 (mm) Coil width	板厚 (mm) Thickness
YLE200	1000	1219	0.4
			0.6

立体效果图
Stereo view

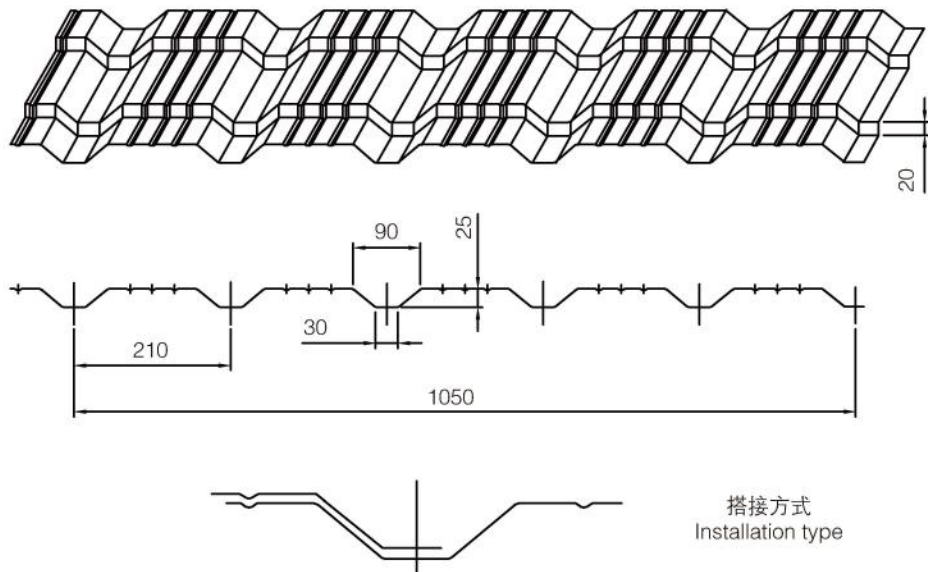

型号 Model	有效覆盖宽度 (mm) Cover width	展开宽度 (mm) Coil width	板厚 (mm) Thickness
YLA210	1050	1250	0.5
			0.6

立体效果图
Stereo view

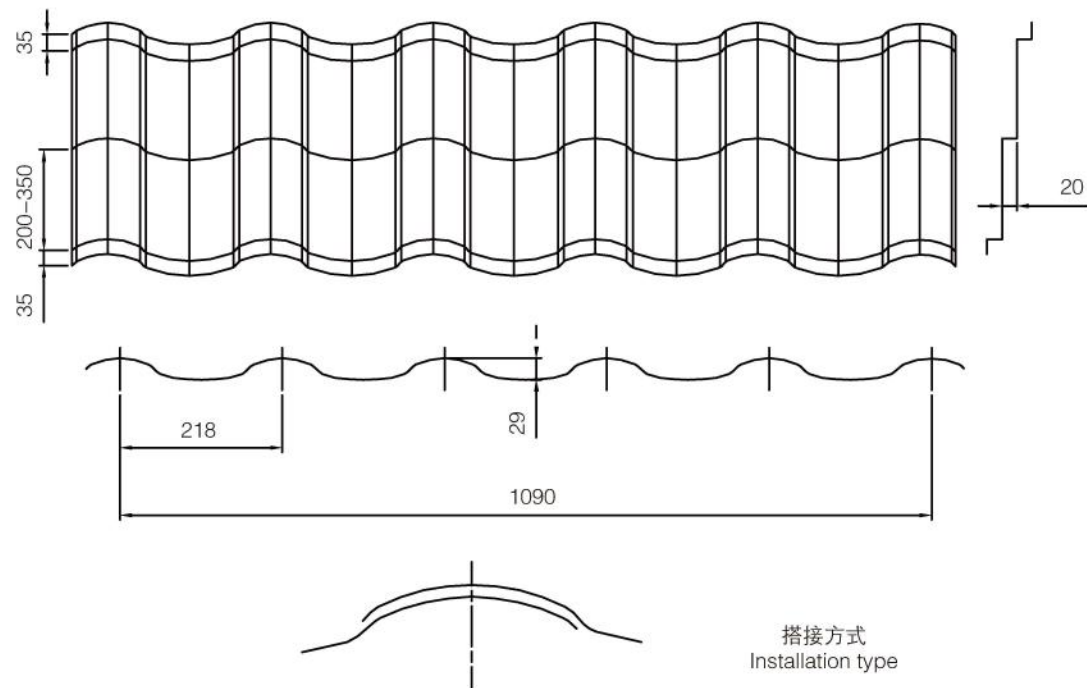

型号 Model	有效覆盖宽度 (mm) Cover width	展开宽度 (mm) Coil width	板厚 (mm) Thickness
YLA218	1090	1250	0.4
			0.6

立体效果图
Stereo view

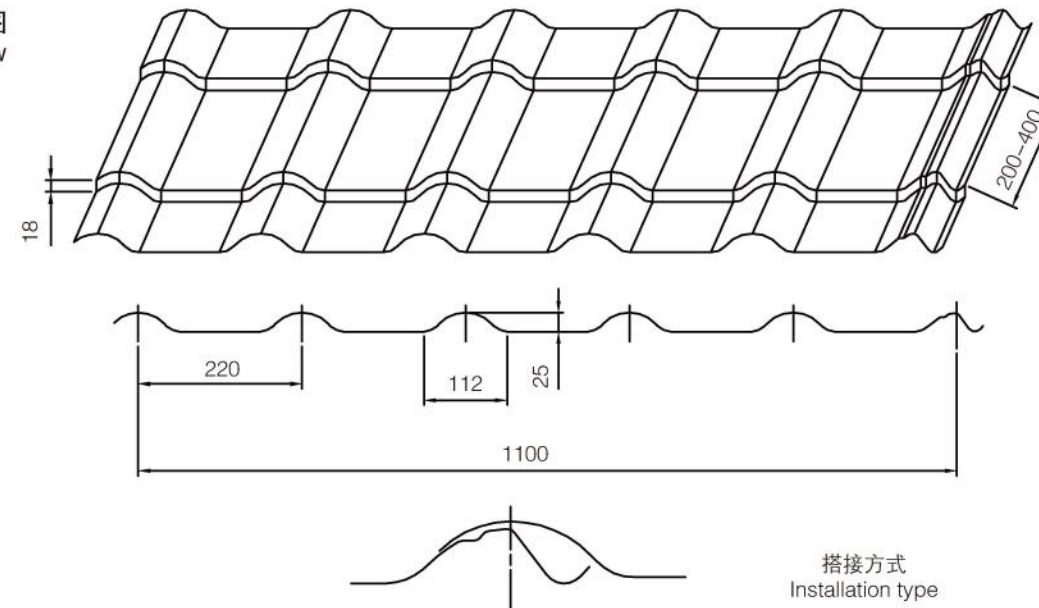

型号 Model	有效覆盖宽度 (mm) Cover width	展开宽度 (mm) Coil width	板厚 (mm) Thickness
YLA220	1100	1250	0.4
			0.6

立体效果图
Stereo view

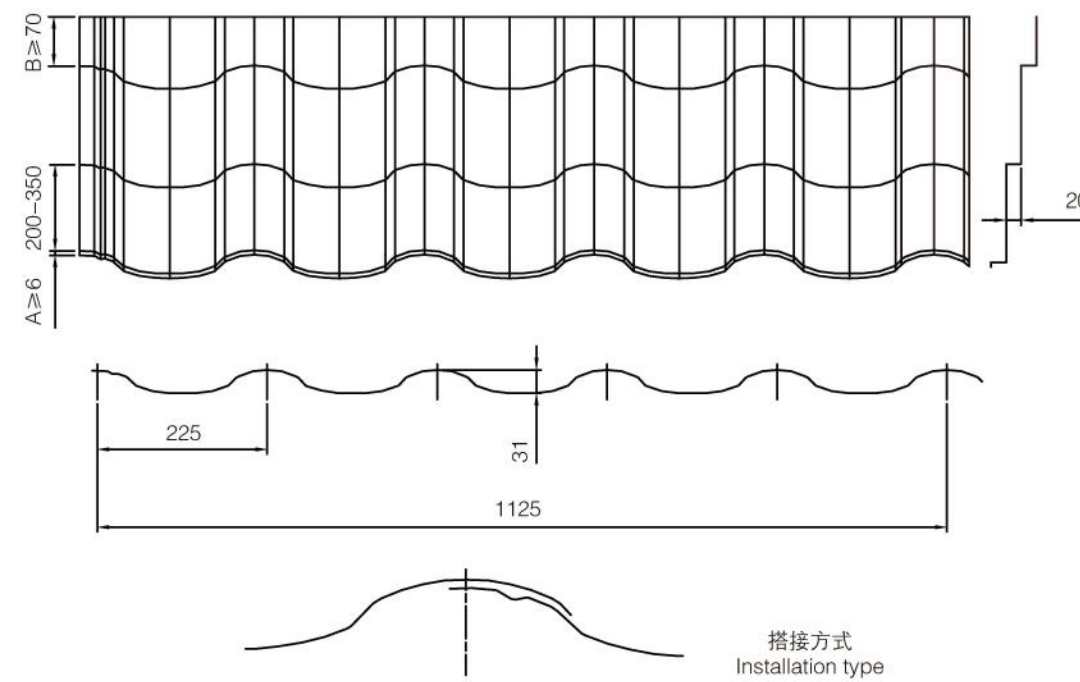

型号 Model	有效覆盖宽度 (mm) Cover width	展开宽度 (mm) Coil width	板厚 (mm) Thickness
YLA225	1125	1250	0.4
			0.6

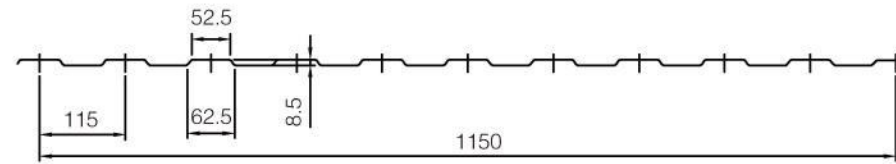

型号 Model	有效覆盖宽度 (mm) Cover width	展开宽度 (mm) Coil width	板厚 (mm) Thickness	用途 Usage
YQA115(C8)	1150	1250	0.4	屋面板 Roof
			0.7	

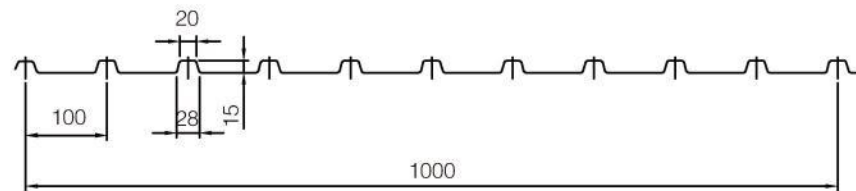

型号 Model	有效覆盖宽度 (mm) Cover width	展开宽度 (mm) Coil width	板厚 (mm) Thickness	用途 Usage
YQC100(C15)	1000	1250	0.4	屋面板 Roof
			0.8	

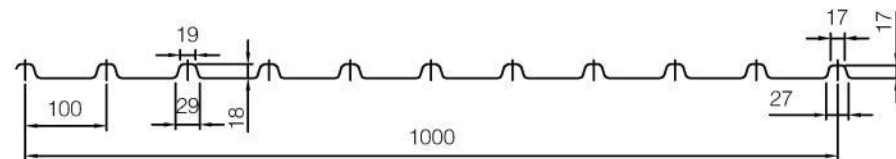

型号 Model	有效覆盖宽度 (mm) Cover width	展开宽度 (mm) Coil width	板厚 (mm) Thickness	用途 Usage
YQB100(C18)	1000	1250	0.4	屋面板 Roof
			0.8	

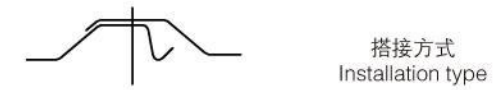
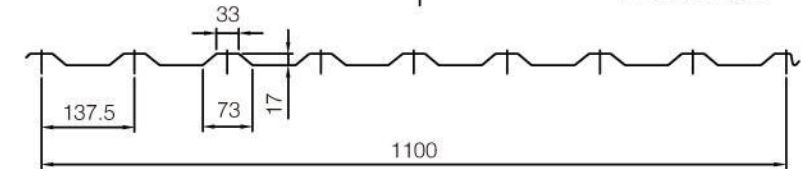
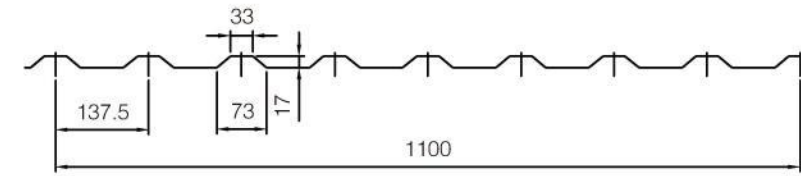

型号 Model	有效覆盖宽度 (mm) Cover width	展开宽度 (mm) Coil width	板厚 (mm) Thickness	用途 Usage
YQF137(C20)	1100	1250	0.4	屋面板 Roof
			0.7	

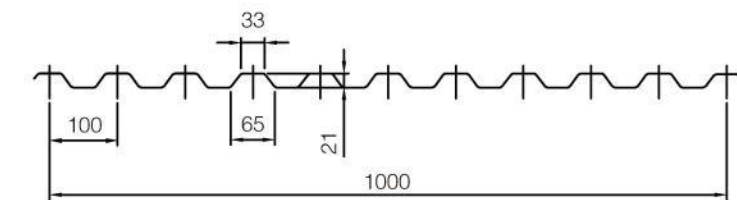

型号 Model	有效覆盖宽度 (mm) Cover width	展开宽度 (mm) Coil width	板厚 (mm) Thickness	用途 Usage
YQA100(C21)	1000	1250	0.4	屋面板 Roof
			0.7	

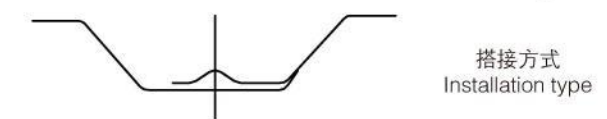
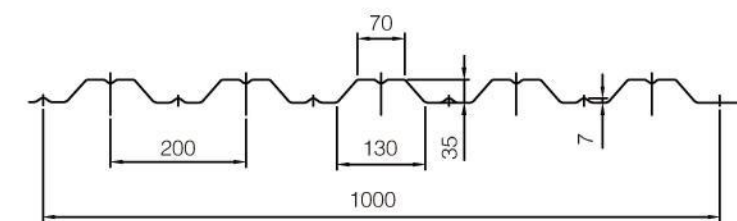

型号 Model	有效覆盖宽度 (mm) Cover width	展开宽度 (mm) Coil width	板厚 (mm) Thickness	用途 Usage
YQB200(HC35)	1000	1250	0.4	屋面板 Roof
			0.7	

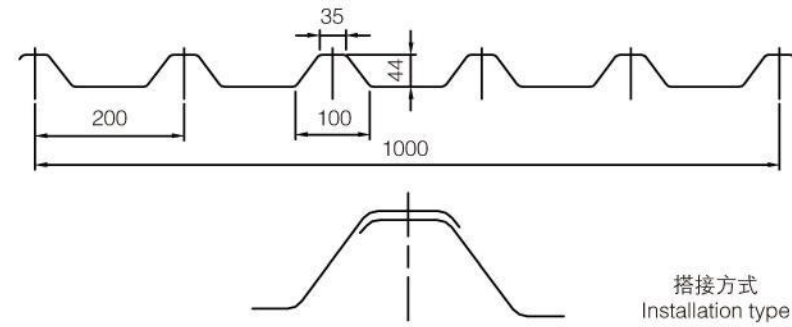

型号 Model	有效覆盖宽度 (mm) Cover width	展开宽度 (mm) Coil width	板厚 (mm) Thickness	用途 Usage
YQA200(C44)	1000	1250	0.4	屋面板 Roof
			0.7	

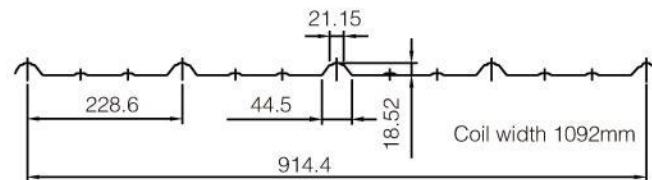
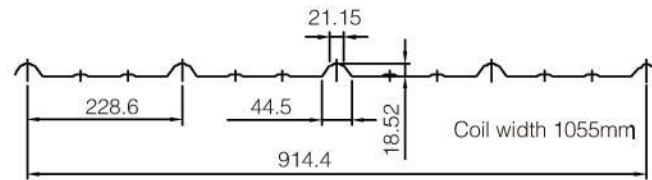
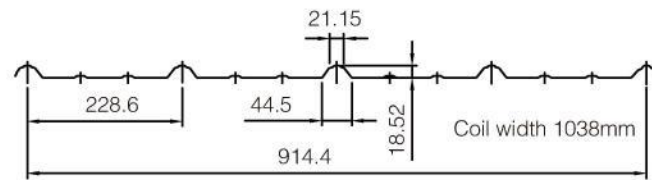

型号 Model	有效覆盖宽度 (mm) Cover width	展开宽度 (mm) Coil width	板厚 (mm) Thickness	用途 Usage
YQA228A	914	1038/1055/1092	0.36	屋面板 Roof
			0.47	

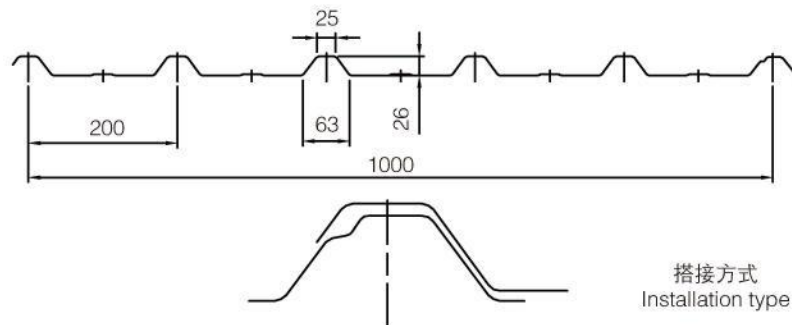

型号 Model	有效覆盖宽度 (mm) Cover width	展开宽度 (mm) Coil width	板厚 (mm) Thickness	用途 Usage
YQM200	1000	1200	0.35	屋面板 Roof
			0.7	

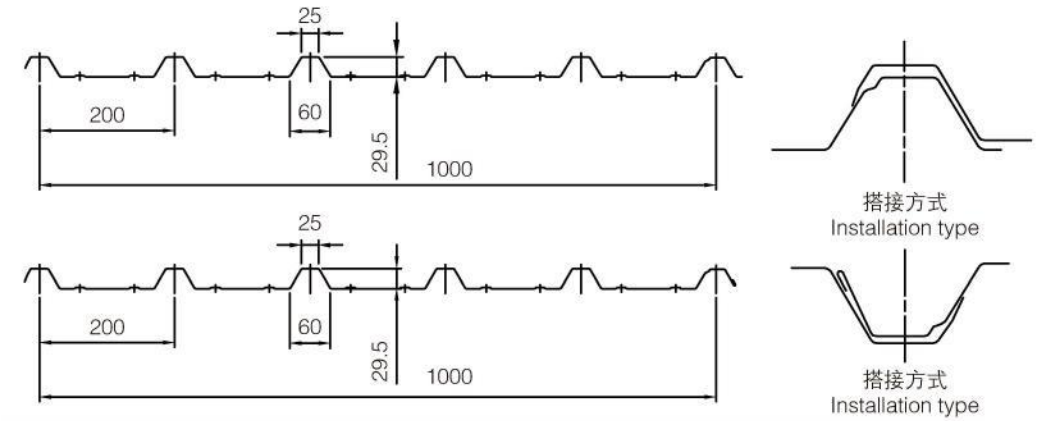

型号 Model	有效覆盖宽度 (mm) Cover width	展开宽度 (mm) Coil width	板厚 (mm) Thickness	用途 Usage
YQS200	1000	1250	0.4	屋面板 Roof
			0.8	

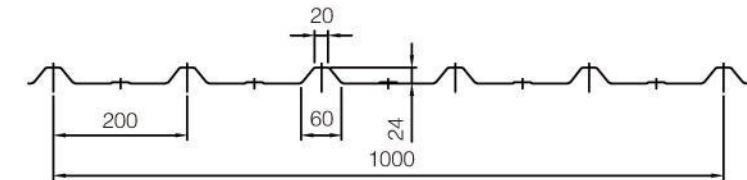

型号 Model	有效覆盖宽度 (mm) Cover width	展开宽度 (mm) Coil width	板厚 (mm) Thickness	用途 Usage
YQT200C	1000	1200	0.3	屋面板 Roof
			0.7	

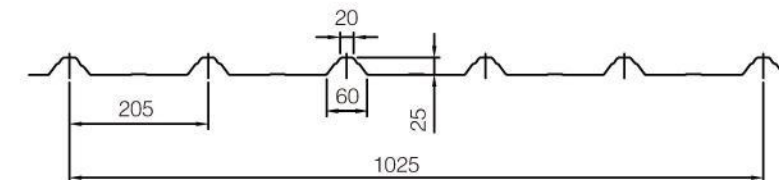
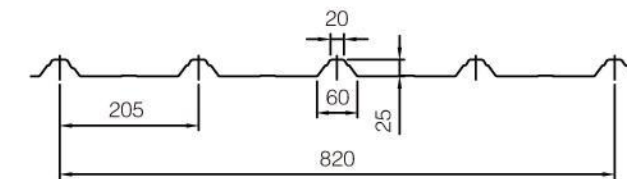

型号 Model	有效覆盖宽度 (mm) Cover width	展开宽度 (mm) Coil width	板厚 (mm) Thickness	用途 Usage
YQA205A	820/1025	1000/1250	0.4	屋面板 Roof
			0.7	

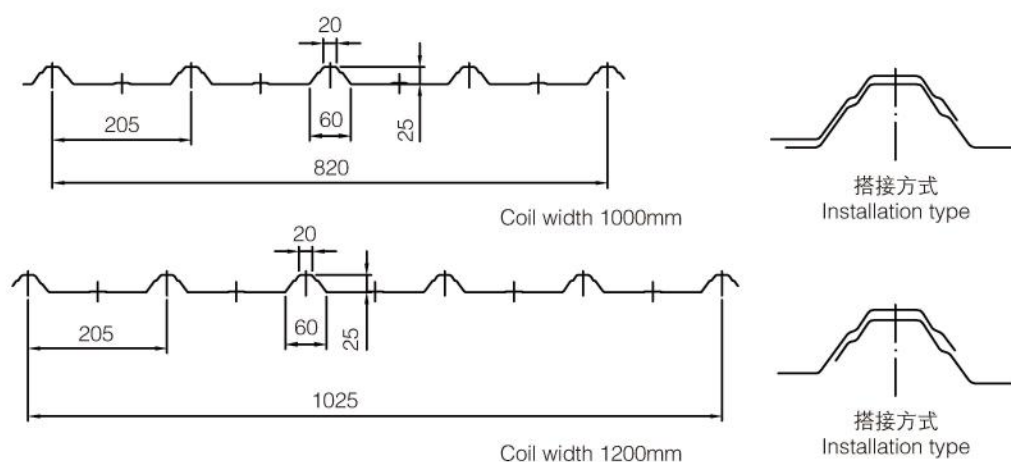

型号 Model	有效覆盖宽度 (mm) Cover width	展开宽度 (mm) Coil width	板厚 (mm) Thickness	用途 Usage
YQC205	820/1025	1000/1200	0.4 0.7	屋面板 Roof

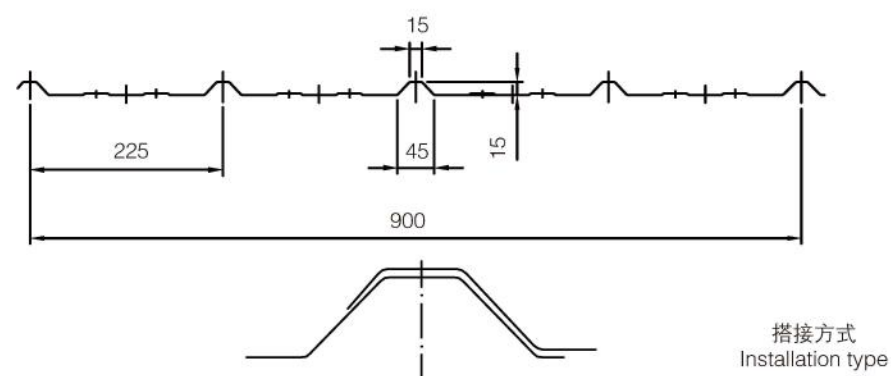

型号 Model	有效覆盖宽度 (mm) Cover width	展开宽度 (mm) Coil width	板厚 (mm) Thickness	用途 Usage
YQA225	900	1200	0.3 0.7	屋面板 Roof

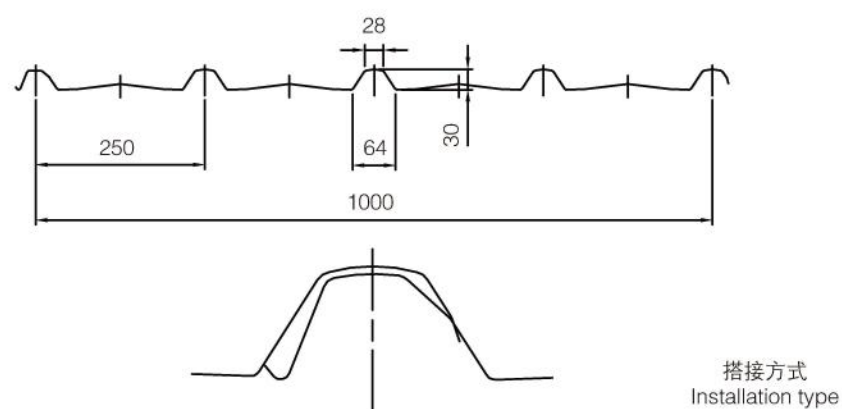

型号 Model	有效覆盖宽度 (mm) Cover width	展开宽度 (mm) Coil width	板厚 (mm) Thickness	用途 Usage
YQA250	1000	1200	0.4 0.7	屋面板 Roof

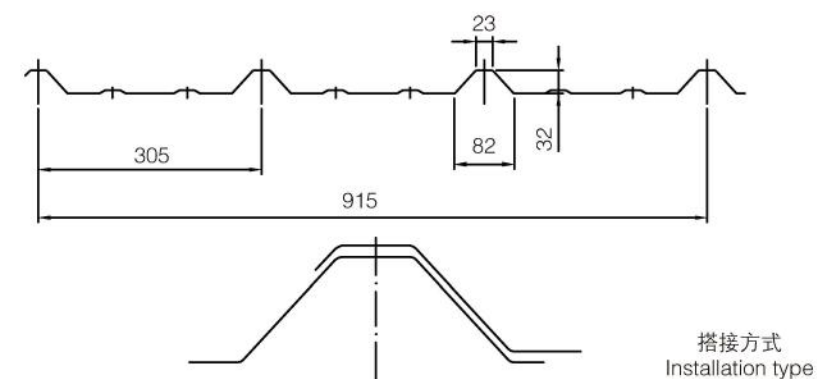

型号 Model	有效覆盖宽度 (mm) Cover width	展开宽度 (mm) Coil width	板厚 (mm) Thickness	用途 Usage
YQA305	915	1092	0.36 0.47	屋面板 Roof

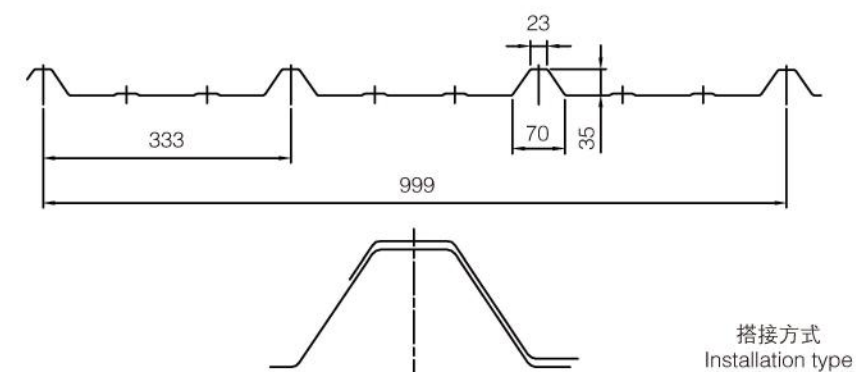

型号 Model	有效覆盖宽度 (mm) Cover width	展开宽度 (mm) Coil width	板厚 (mm) Thickness	用途 Usage
YQB333	999	1200	0.35 0.5	屋面板 Roof

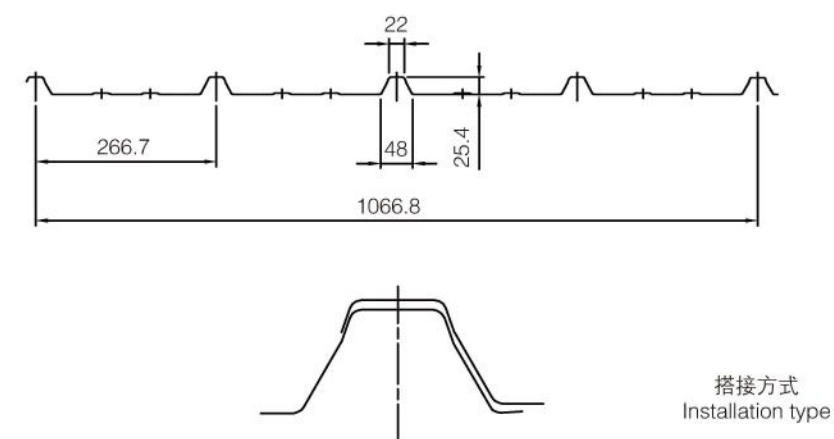

型号 Model	有效覆盖宽度 (mm) Cover width	展开宽度 (mm) Coil width	板厚 (mm) Thickness	用途 Usage
YQA266	1066	1250	0.37 0.61	屋面板 Roof

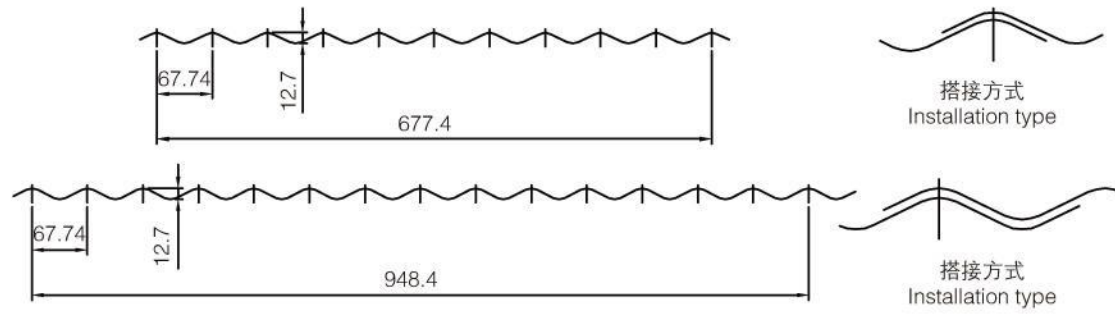

型号 Model	有效覆盖宽度 (mm) Cover width	展开宽度 (mm) Coil width	板厚 (mm) Thickness	用途 Usage
YQA66	677/948	760/1092	0.37	屋面板 Roof
			0.76	

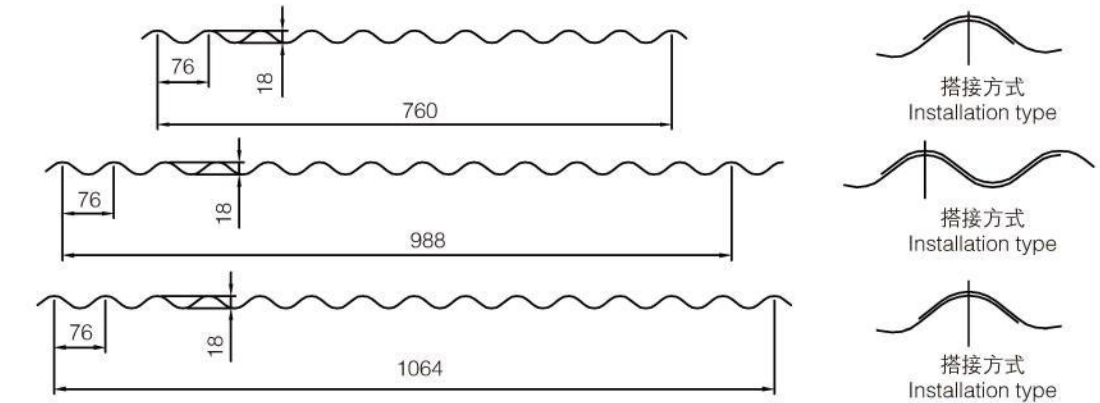

型号 Model	有效覆盖宽度 (mm) Cover width	展开宽度 (mm) Coil width	板厚 (mm) Thickness	用途 Usage
YQA76	760/988/1064	900/1220/1250	0.4	屋面板 Roof
			0.6	

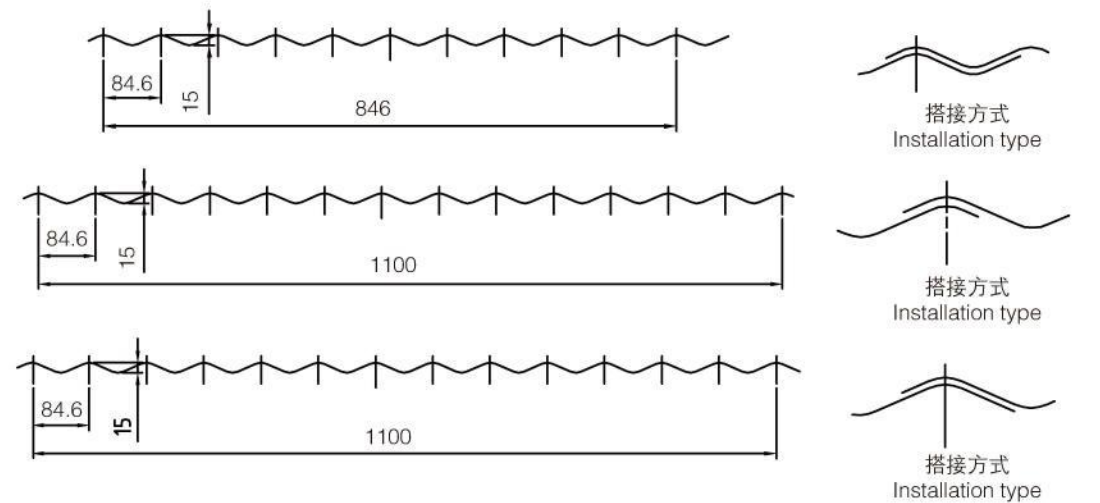

型号 Model	有效覆盖宽度 (mm) Cover width	展开宽度 (mm) Coil width	板厚 (mm) Thickness	用途 Usage
YQA84	846/1100	1000/1200/1220	0.4	屋面板 Roof
			0.8	

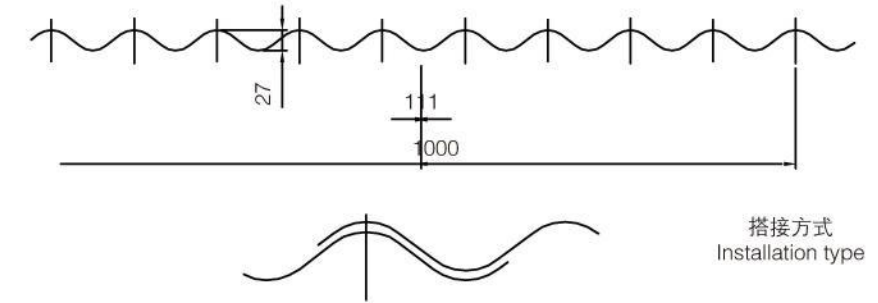

型号 Model	有效覆盖宽度 (mm) Cover width	展开宽度 (mm) Coil width	板厚 (mm) Thickness	用途 Usage
YQA111	1000	1250	0.45	屋面板 Roof
			0.75	

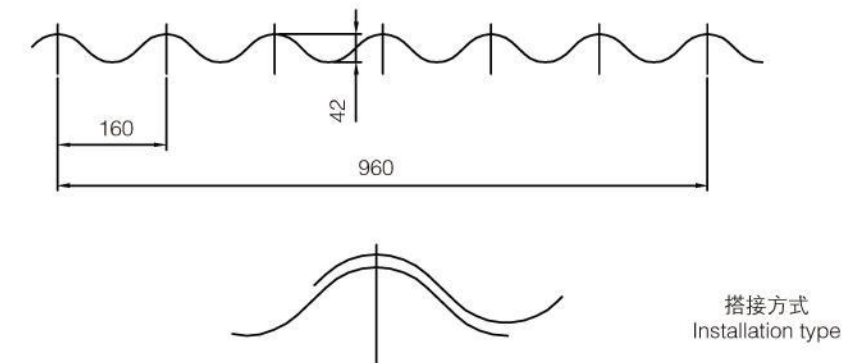

型号 Model	有效覆盖宽度 (mm) Cover width	展开宽度 (mm) Coil width	板厚 (mm) Thickness	用途 Usage
YQA160	960	1250	0.45	屋面板 Roof
			0.75	

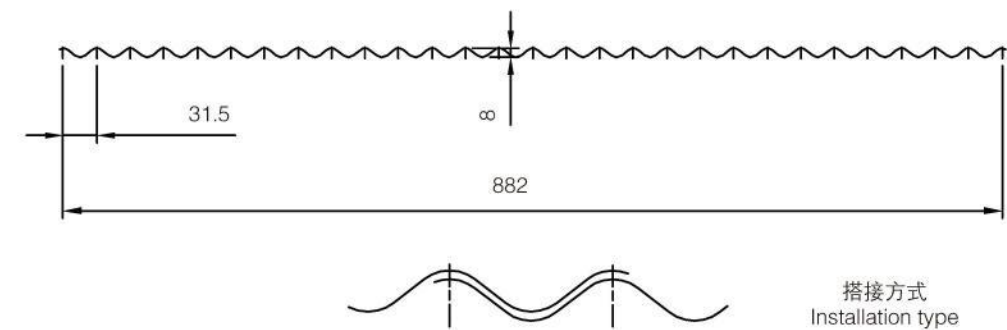

型号 Model	有效覆盖宽度 (mm) Cover width	展开宽度 (mm) Coil width	板厚 (mm) Thickness	用途 Usage
YQA32A	882	1000	0.35	屋面板 Roof
			0.5	

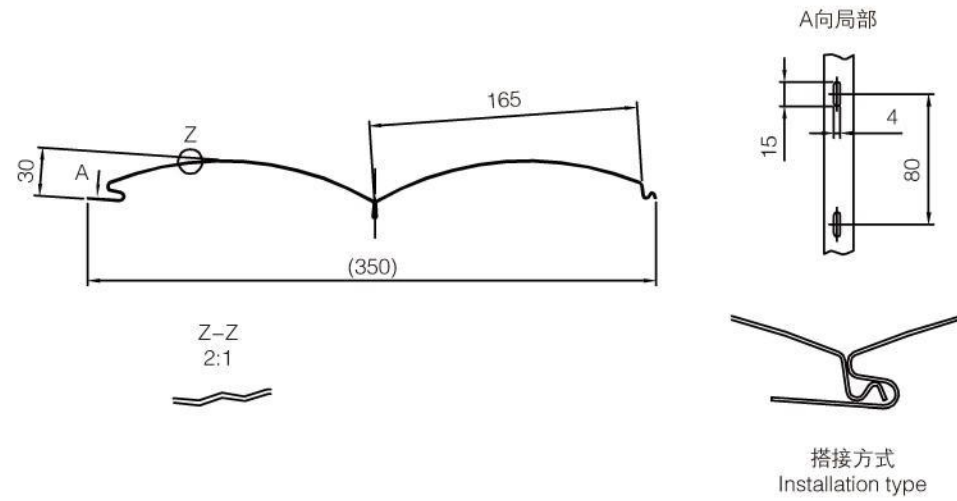

型号 Model	有效覆盖宽度 (mm) Cover width	展开宽度 (mm) Coil width	板厚 (mm) Thickness	用途 Usage
YKB165	350	416	0.45 0.7	隐藏式墙面板 Joint-hidden Wall

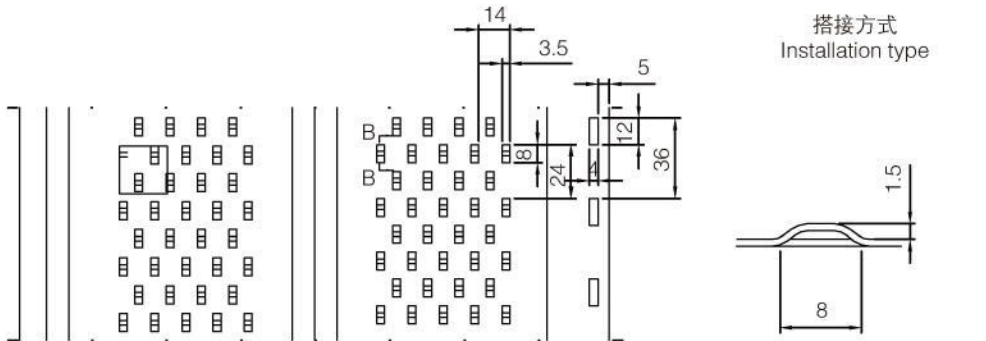
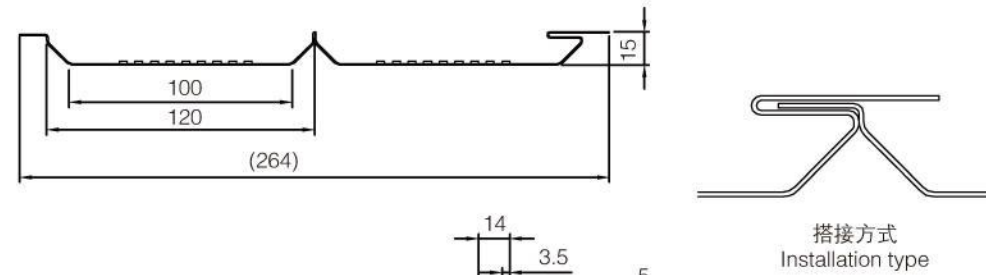

型号 Model	有效覆盖宽度 (mm) Cover width	展开宽度 (mm) Coil width	板厚 (mm) Thickness	用途 Usage
YKA264	264	325	0.45 0.7	隐藏式墙面板 Joint-hidden Wall

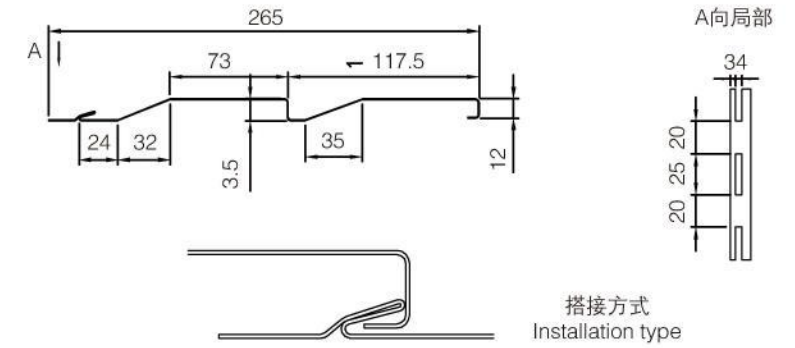

型号 Model	有效覆盖宽度 (mm) Cover width	展开宽度 (mm) Coil width	板厚 (mm) Thickness	用途 Usage
YWA265	265	315	0.4 0.6	隐藏式墙面板 Joint-hidden Wall

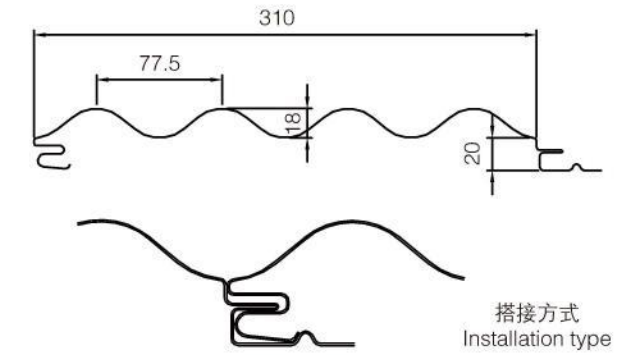

型号 Model	有效覆盖宽度 (mm) Cover width	展开宽度 (mm) Coil width	板厚 (mm) Thickness	用途 Usage
YWA77	310	500	0.5 0.6	隐藏式墙面板 Joint-hidden Wall

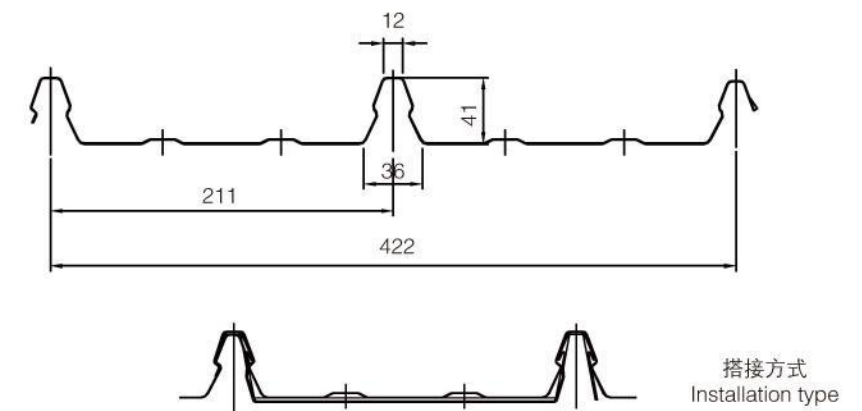

型号 Model	有效覆盖宽度 (mm) Cover width	展开宽度 (mm) Coil width	板厚 (mm) Thickness	用途 Usage
YWA211	422	600	0.4 0.7	隐藏式屋面 Joint-hidden Roof

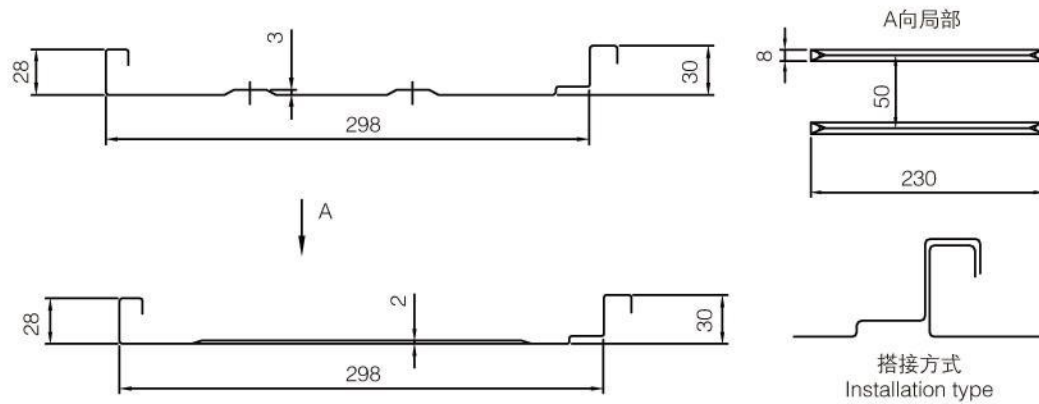

型号 Model	有效覆盖宽度 (mm) Cover width	展开宽度 (mm) Coil width	板厚 (mm) Thickness	用途 Usage
YWA298	298	400	0.65	咬合式屋面板 Self-locked Roof

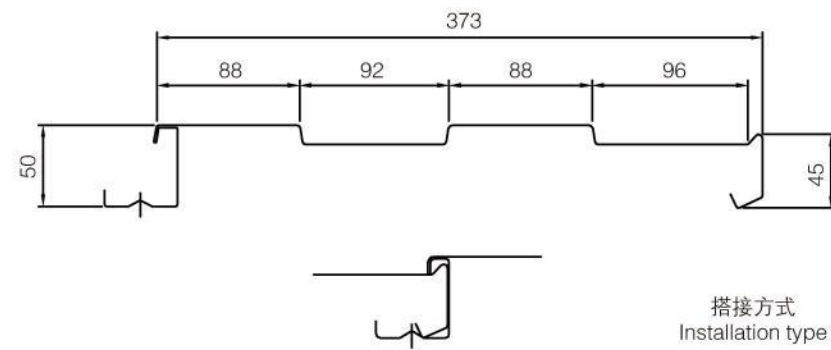

型号 Model	有效覆盖宽度 (mm) Cover width	展开宽度 (mm) Coil width	板厚 (mm) Thickness	用途 Usage
YWA373	373	600	0.4 0.7	咬合式墙面板 Self-locked Wall

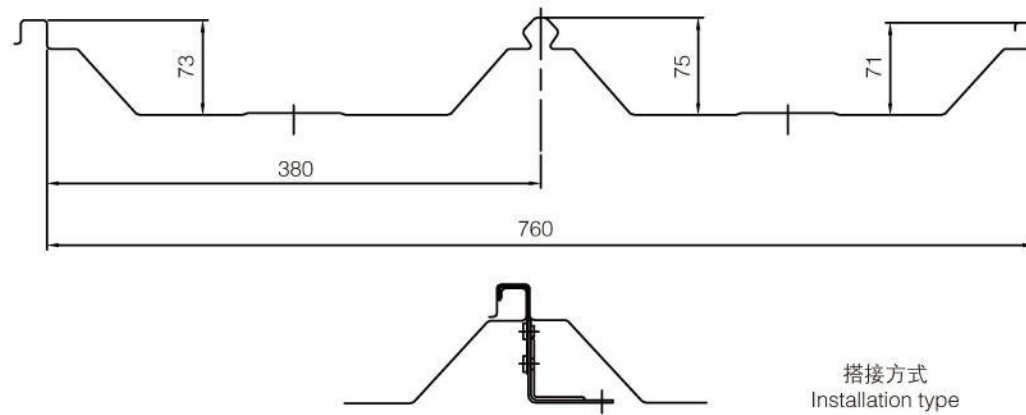

型号 Model	有效覆盖宽度 (mm) Cover width	展开宽度 (mm) Coil width	板厚 (mm) Thickness	用途 Usage
YWA380	760	1000	0.4 0.7	咬合式屋面板 Self-locked Roof

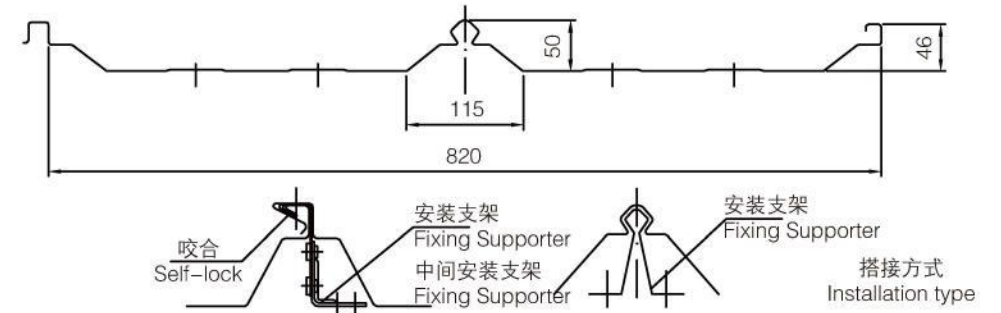

型号 Model	有效覆盖宽度 (mm) Cover width	展开宽度 (mm) Coil width	板厚 (mm) Thickness	用途 Usage
YWA410	820	1000	0.5 0.8	咬合式屋面板 Self-locked Roof

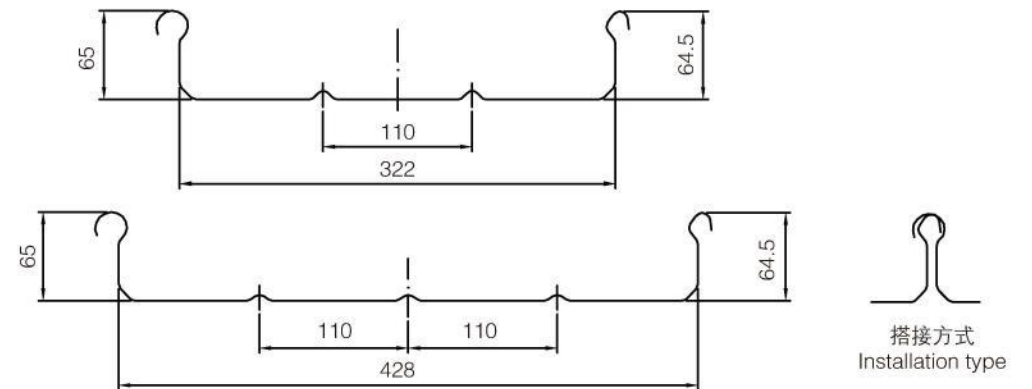

型号 Model	有效覆盖宽度 (mm) Cover width	展开宽度 (mm) Coil width	板厚 (mm) Thickness	用途 Usage
YWA428	322/428	500/600	0.6 1.0	咬合式屋面板 Self-locked Roof

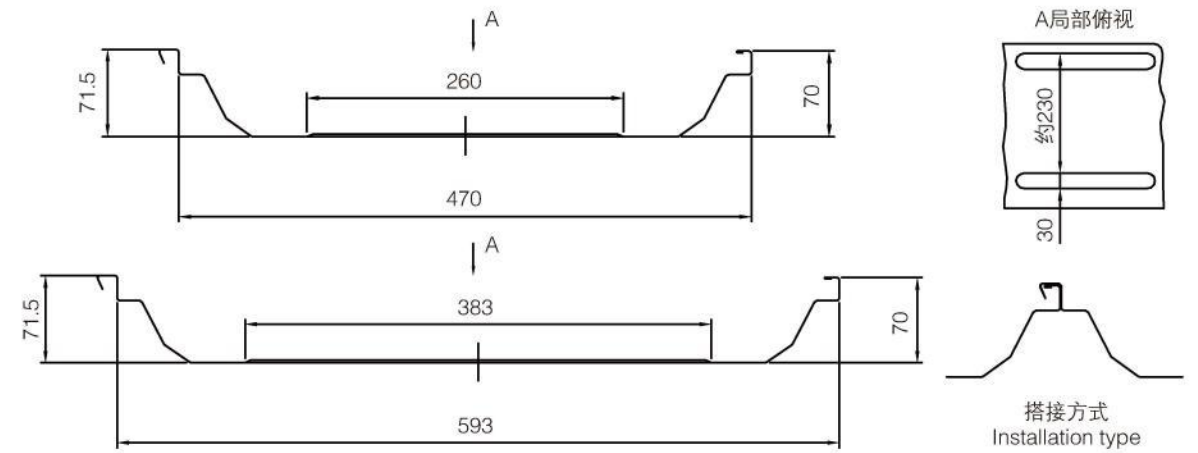

型号 Model	有效覆盖宽度 (mm) Cover width	展开宽度 (mm) Coil width	板厚 (mm) Thickness	用途 Usage
YWA593	470/593	600/725	0.4 0.7	咬合式屋面板 Self-locked Roof

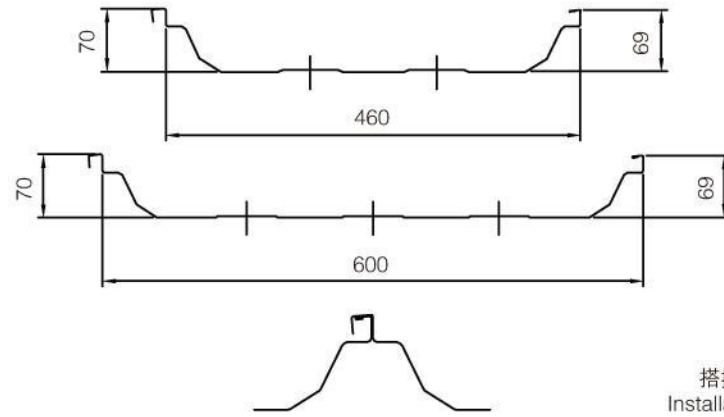

搭接方式
Installation type

型号 Model	有效覆盖宽度 (mm) Cover width	展开宽度 (mm) Coil width	板厚 (mm) Thickness	用途 Usage
YWA600	460/600	590/730	0.5	咬合式屋面板 Self-locked Roof
			0.7	

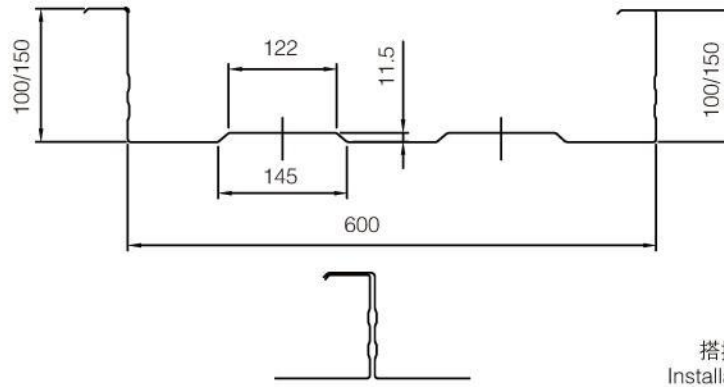

搭接方式
Installation type

型号 Model	有效覆盖宽度 (mm) Cover width	展开宽度 (mm) Coil width	板厚 (mm) Thickness	用途 Usage
YWD600	600	1000	0.7	咬合式屋面板 Self-locked Roof
			0.9	

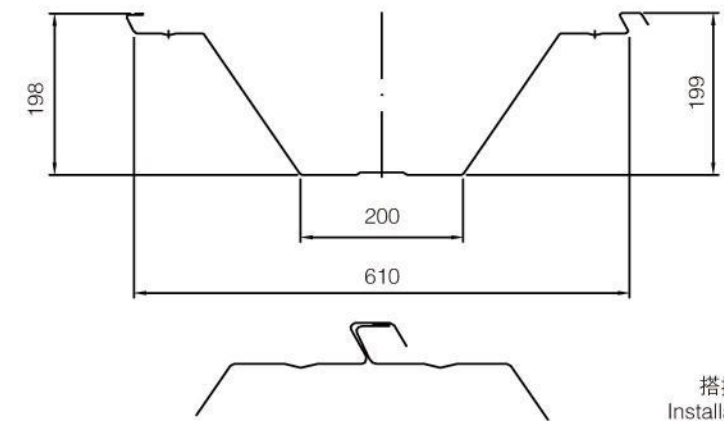

搭接方式
Installation type

型号 Model	有效覆盖宽度 (mm) Cover width	展开宽度 (mm) Coil width	板厚 (mm) Thickness	用途 Usage
YWA610	610	914	0.8	咬合式屋面板 Self-locked Roof
			1.2	

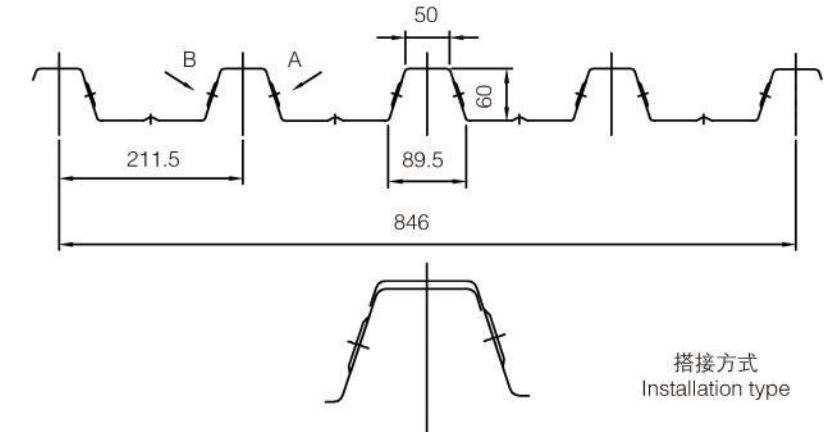

搭接方式
Installation type

型号 Model	有效覆盖宽度 (mm) Cover width	展开宽度 (mm) Coil width	板厚 (mm) Thickness	用途 Usage
YGA211(H60)	846	1250	0.5	钢楼板 Deck
			1.0	

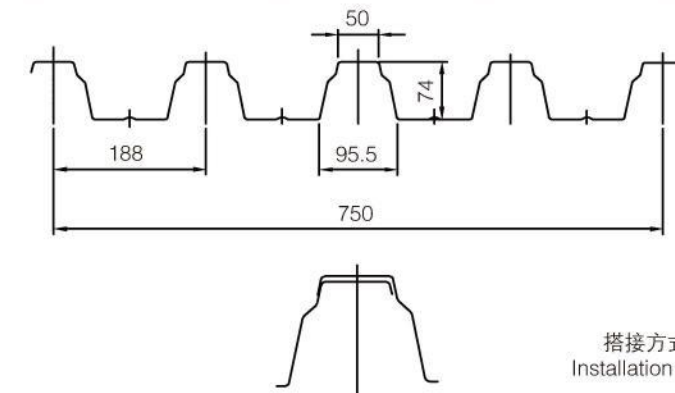

搭接方式
Installation type

型号 Model	有效覆盖宽度 (mm) Cover width	展开宽度 (mm) Coil width	板厚 (mm) Thickness	用途 Usage
YGA188(H75)	750	1250	0.6	钢楼板 Deck
			1.0	

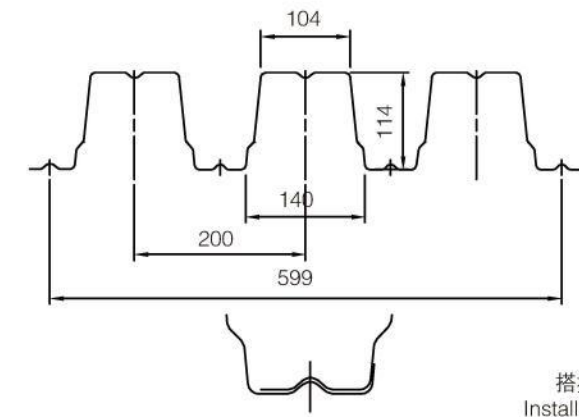

搭接方式
Installation type

型号 Model	有效覆盖宽度 (mm) Cover width	展开宽度 (mm) Coil width	板厚 (mm) Thickness	用途 Usage
YGD200(H114)	599	1250	0.8	钢楼板 Deck
			1.2	

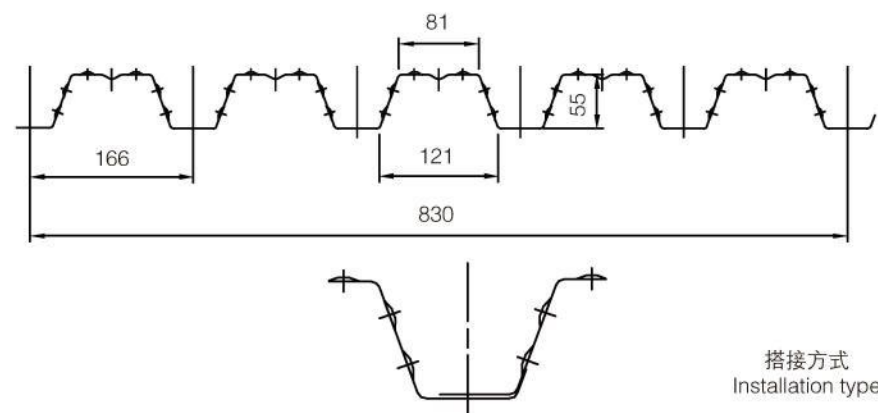

型号 Model	有效覆盖宽度 (mm) Cover width	展开宽度 (mm) Coil width	板厚 (mm) Thickness	用途 Usage
YGA166	830	1250	0.8 1.2	钢楼板 Deck

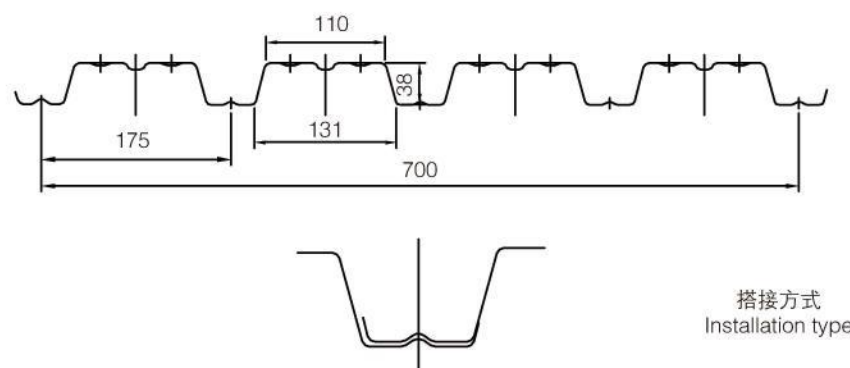

型号 Model	有效覆盖宽度 (mm) Cover width	展开宽度 (mm) Coil width	板厚 (mm) Thickness	用途 Usage
YGA175	700	1000	0.7 1.2	钢楼板 Deck

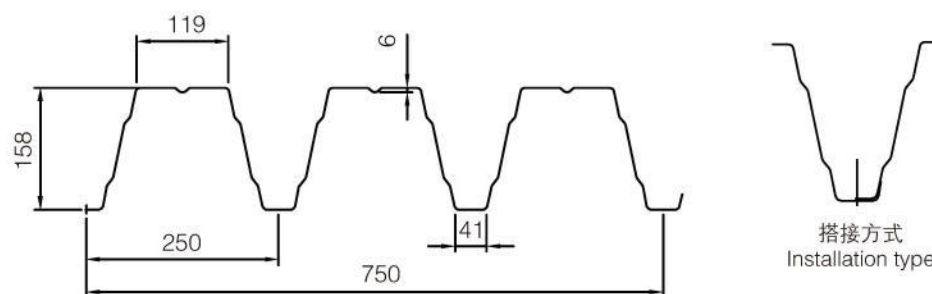

型号 Model	有效覆盖宽度 (mm) Cover width	展开宽度 (mm) Coil width	板厚 (mm) Thickness	用途 Usage
YGA250	750	1500	0.7 1.25	钢楼板 Deck

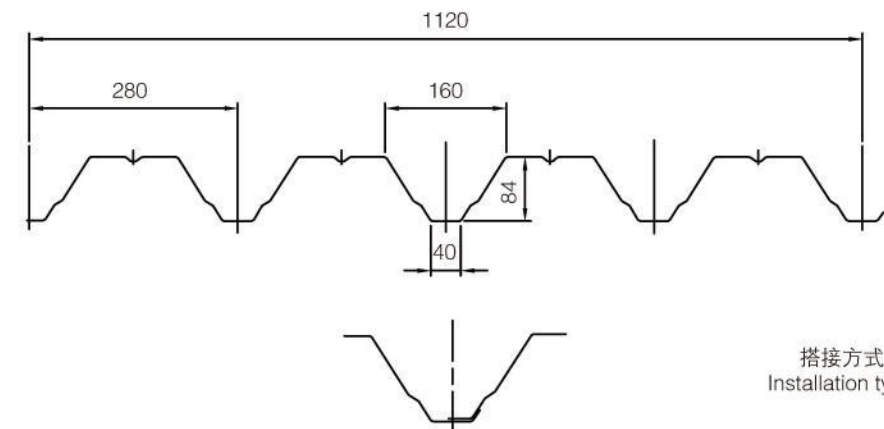

型号 Model	有效覆盖宽度 (mm) Cover width	展开宽度 (mm) Coil width	板厚 (mm) Thickness	用途 Usage
YGA280	1120	1500	0.75 1.25	钢楼板 Deck

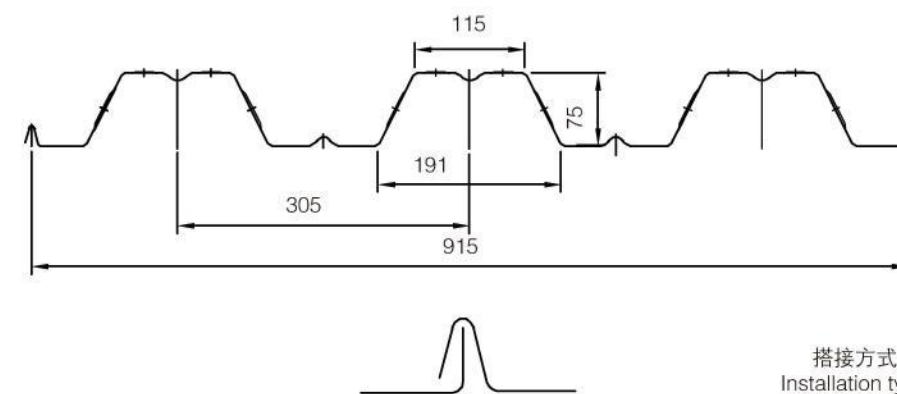

型号 Model	有效覆盖宽度 (mm) Cover width	展开宽度 (mm) Coil width	板厚 (mm) Thickness	用途 Usage
YGA305	915	1250	0.8 1.2	钢楼板 Deck

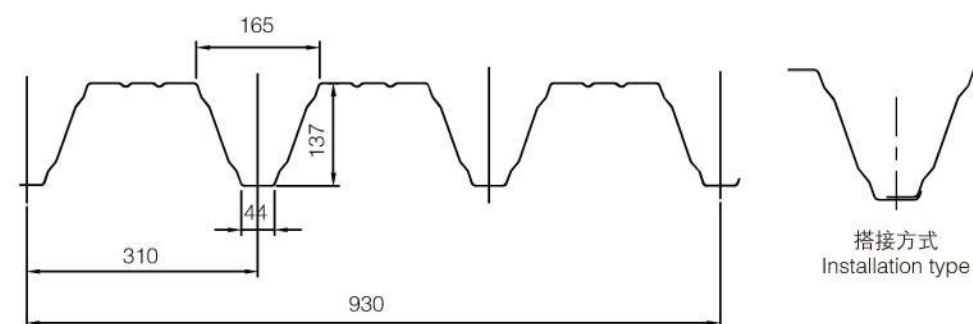

型号 Model	有效覆盖宽度 (mm) Cover width	展开宽度 (mm) Coil width	板厚 (mm) Thickness	用途 Usage
YGA310	930	1500	0.8 1.25	钢楼板 Deck

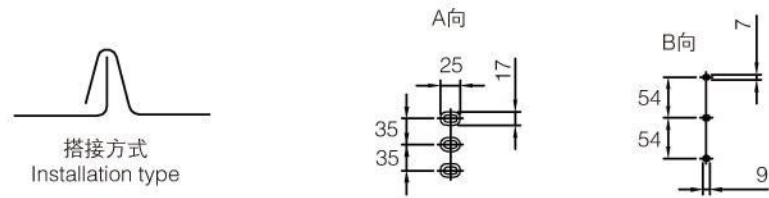
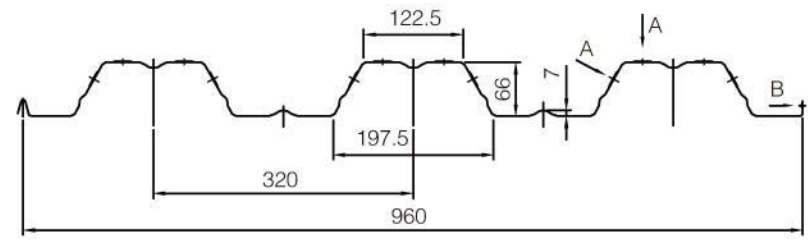

型号 Model	有效覆盖宽度 (mm) Cover width	展开宽度 (mm) Coil width	板厚 (mm) Thickness	用途 Usage
YGA320	960	1250	0.7 1.2	钢楼板 Deck

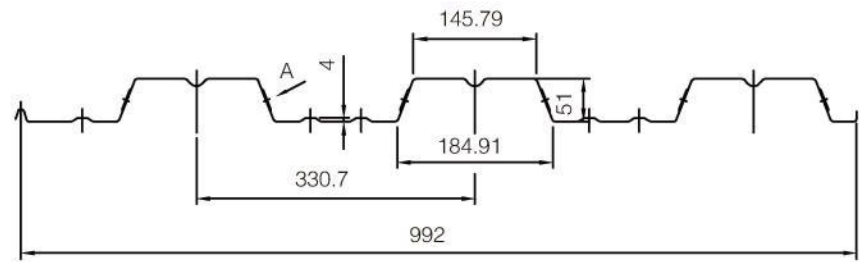

型号 Model	有效覆盖宽度 (mm) Cover width	展开宽度 (mm) Coil width	板厚 (mm) Thickness	用途 Usage
YGA331	992	1250	0.8 1.2	钢楼板 Deck

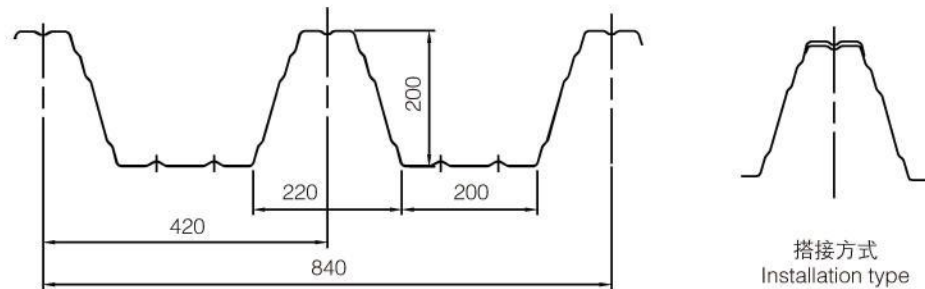
 搭接方式
 Installation type

型号 Model	有效覆盖宽度 (mm) Cover width	展开宽度 (mm) Coil width	板厚 (mm) Thickness	用途 Usage
YGA420	840	1500	0.7 1.25	钢楼板 Deck

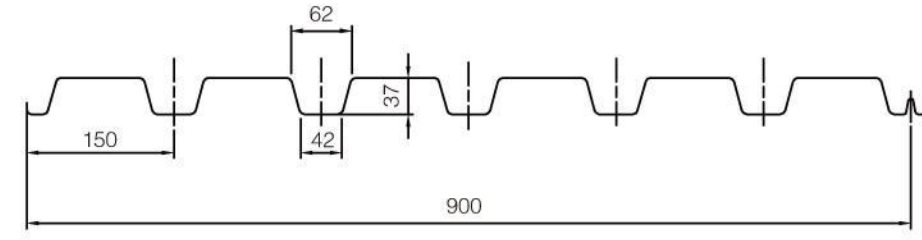
 搭接方式
 Installation type

型号 Model	有效覆盖宽度 (mm) Cover width	展开宽度 (mm) Coil width	板厚 (mm) Thickness	用途 Usage
YGA150	900	1250	0.7 1.2	钢楼板 Deck

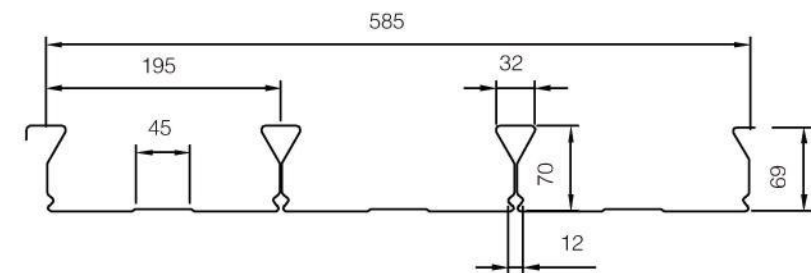
 搭接方式
 Installation type

型号 Model	有效覆盖宽度 (mm) Cover width	展开宽度 (mm) Coil width	板厚 (mm) Thickness	用途 Usage
YGA195	585	1125	0.8 1.0	钢楼板 Deck

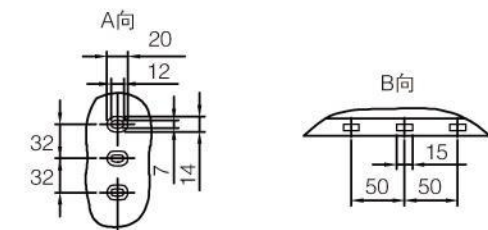
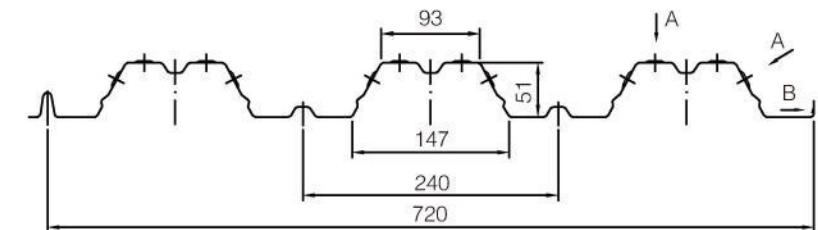
 搭接方式
 Installation type

型号 Model	有效覆盖宽度 (mm) Cover width	展开宽度 (mm) Coil width	板厚 (mm) Thickness	用途 Usage
YGA240	720	1000	0.8 1.2	钢楼板 Deck

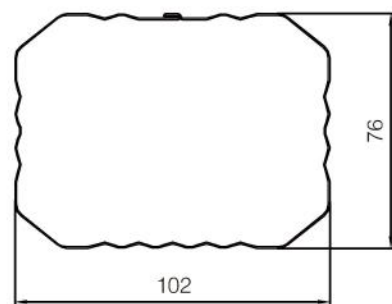

型号 Model	展开宽度 (mm) Coil width	板厚 (mm) Thickness	用途 Usage
YBF102	338	0.5	落水管 Water Pipe
		0.6	

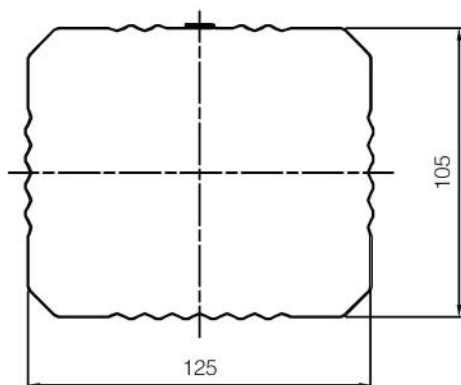

型号 Model	展开宽度 (mm) Coil width	板厚 (mm) Thickness	用途 Usage
YBF125	476	0.5	落水管 Water Pipe

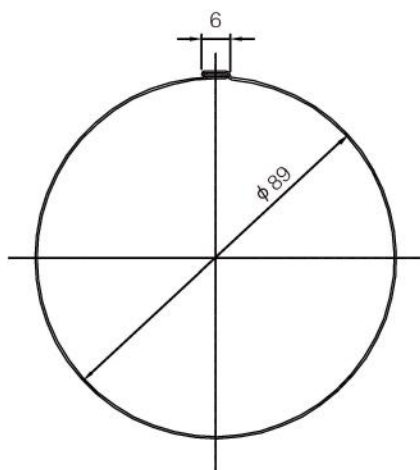

型号 Model	展开宽度 (mm) Coil width	板厚 (mm) Thickness	用途 Usage
YBA89	295	0.5	落水管 Water Pipe
		0.6	

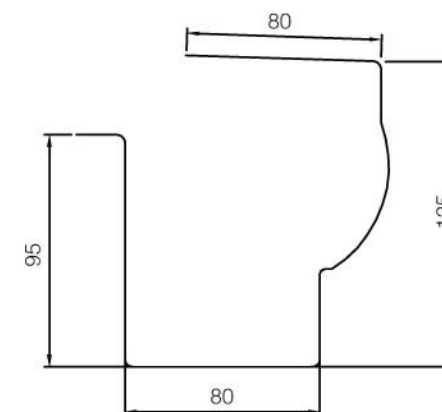

型号 Model	展开宽度 (mm) Coil width	板厚 (mm) Thickness	用途 Usage
YKA80	405	0.4	水槽 Gutter
		0.65	

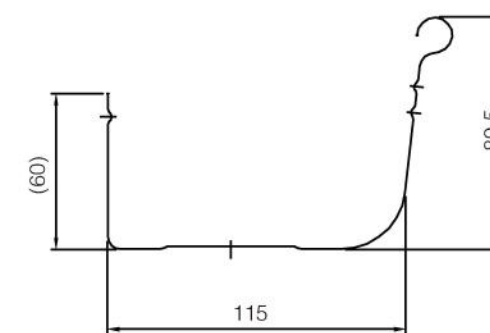

型号 Model	展开宽度 (mm) Coil width	板厚 (mm) Thickness	用途 Usage
YKA115	270	0.42	水槽 Gutter

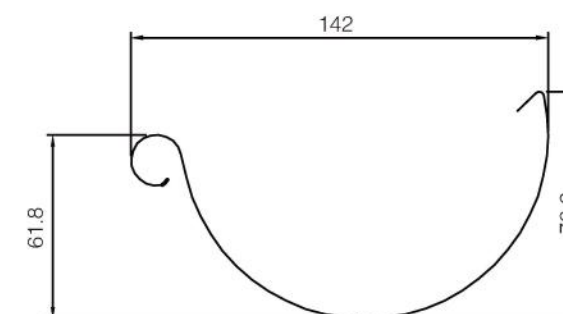

型号 Model	展开宽度 (mm) Coil width	板厚 (mm) Thickness	用途 Usage
YKA142	250	0.5	水槽 Gutter
		0.6	

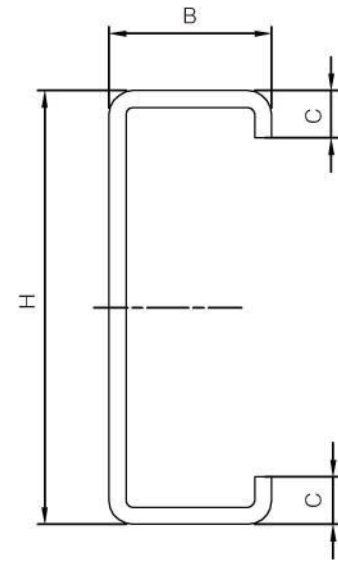
C型檩条规格
 Sizes of C-shape purlins

序号 NO	H (mm)	B (mm)	C (mm)	T (mm)	L (mm)	展开长度(mm) Coil width	备注 Remark LCA300
1	80	40	15	2.0~3.0	40~220	172	○
2	100	40	15	2.0~3.0	40~220	192	√
	100	50	20	2.0~3.0	40~220	222	√
	100	60	20	2.0~3.0	40~220	242	√
3	120	50	20	2.0~3.0	40~220	242	√
	120	60	20	2.0~3.0	40~220	262	√
4	140	50	20	2.0~3.0	40~220	262	√
	140	60	20	2.0~3.0	40~220	282	√
5	160	60	20	2.0~3.0	40~220	302	√
	160	70	20	2.0~3.0	40~220	322	√
6	180	60	20	2.0~3.0	40~220	322	√
	180	70	20	2.0~3.0	40~220	342	√
7	200	60	20	2.0~3.0	40~220	342	√
	200	70	20	2.0~3.0	40~220	362	√
8	220	70	20	2.0~3.0	40~220	382	√
	220	80	20	2.0~3.0	40~220	402	√
9	240	70	20	2.0~3.0	40~220	402	√
	240	80	20	2.0~3.0	40~220	422	√
10	250	80	20	2.0~3.0	40~220	432	○
11	260	80	20	2.0~3.0	40~220	442	○
12	280	80	20	2.0~3.0	40~220	462	○
13	300	80	20	2.0~3.0	40~220	482	○

注：1、带“√”的檩条规格为标准配置
 2、带“○”的檩条规格为选择配置

Note: 1. The size with "√" is company's standard configuration.
 2. The size with "○" is optional configuration.

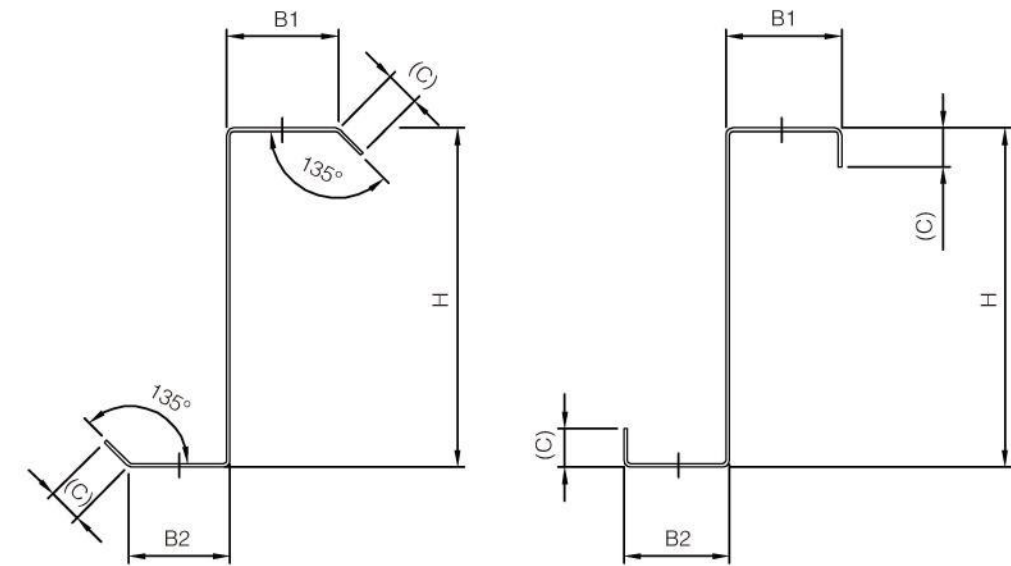
Z型檩条规格
 Sizes of Z-shape purlins

序号 NO	A (mm)	B (mm)	C (mm)	T (mm)	L (mm)	展开长度(mm) Coil width	备注 Remark LZA300
1	100	54	50	2.0~3.0	40~300	234	√
2	120	64	60	2.0~3.0	40~300	274	√
3	140	64	60	2.0~3.0	40~300	294	√
4	160	74	70	2.0~3.0	40~300	334	√
5	180	74	70	2.0~3.0	54~300	354	√
6	200	74	70	2.0~3.0	74~300	374	√
7	220	84	80	2.0~3.0	114~300	414	√
8	240	84	80	2.0~3.0	134~300	434	√
9	260	84	80	2.0~3.0	154~300	454	○
10	280	84	80	2.0~3.0	174~300	474	○
11	300	84	80	2.0~3.0	194~300	494	○

注：1、带“√”的檩条规格为标准配置
 2、带“○”的檩条规格为选择配置

Note: 1. The size with "√" is company's standard configuration.
 2. The size with "○" is optional configuration.

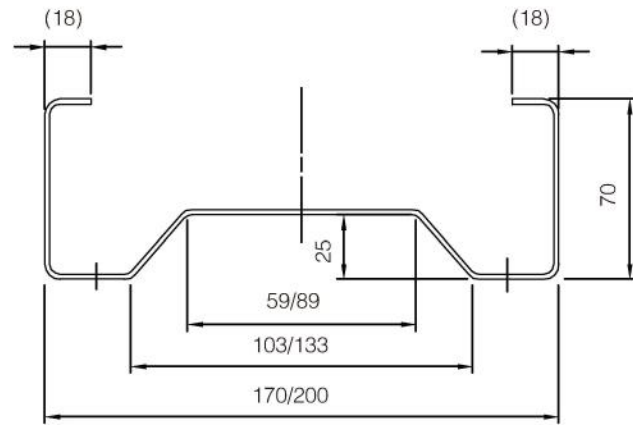

型号 Model	有效覆盖宽度 (mm) Cover width	展开宽度 (mm) Coil width	板厚 (mm) Thickness
LMA200	170/200	348/378	1.5
			2.0

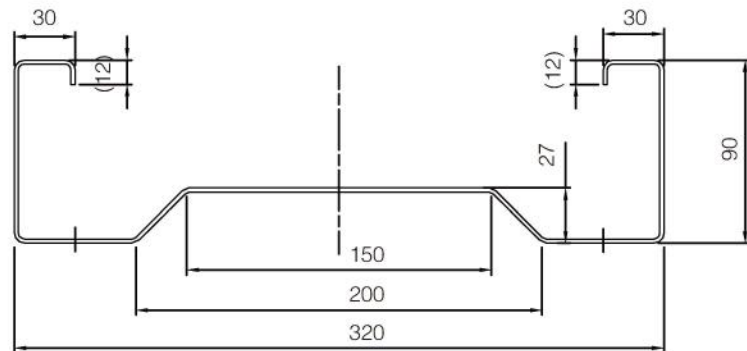
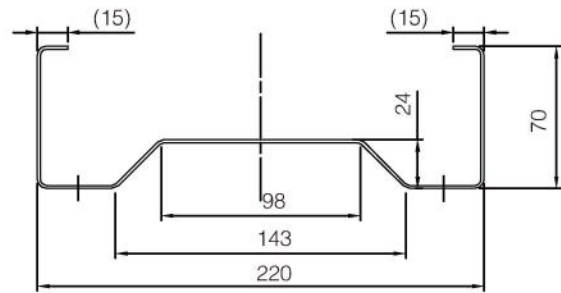

型号 Model	有效覆盖宽度 (mm) Cover width	展开宽度 (mm) Coil width	板厚 (mm) Thickness
LMA-320(220)	320/220	580/395	1.5
			2.0

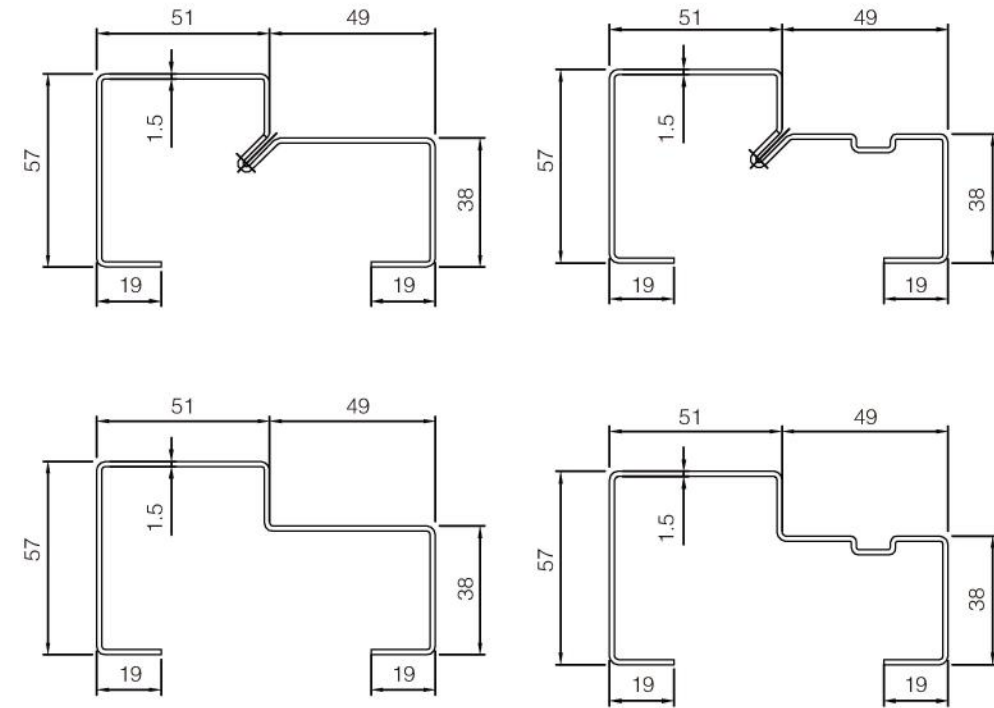

型号 Model	有效覆盖宽度 (mm) Cover width	展开宽度 (mm) Coil width	板厚 (mm) Thickness	用途 Usage
YKA57	100	300	1.0-2.0	门框 Door frame

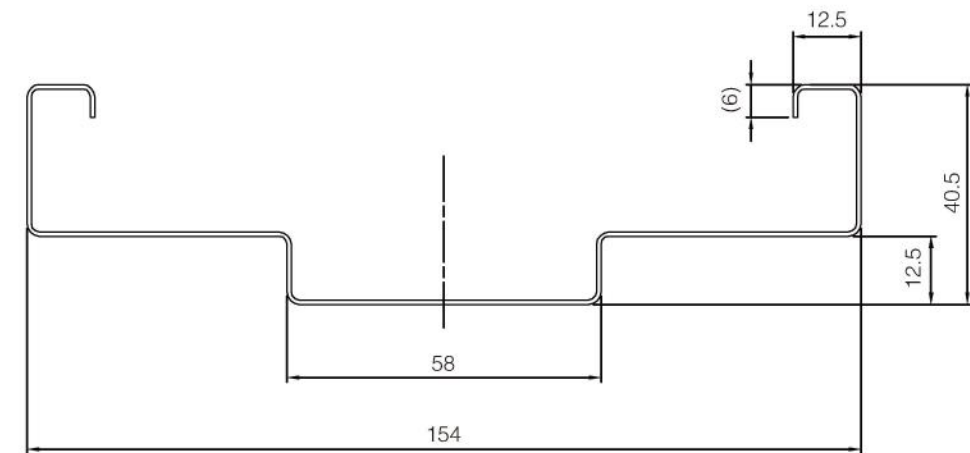

型号 Model	有效覆盖宽度 (mm) Cover width	展开宽度 (mm) Coil width	板厚 (mm) Thickness	用途 Usage
YKA154	154	255	0.46-0.8	门框 Door frame

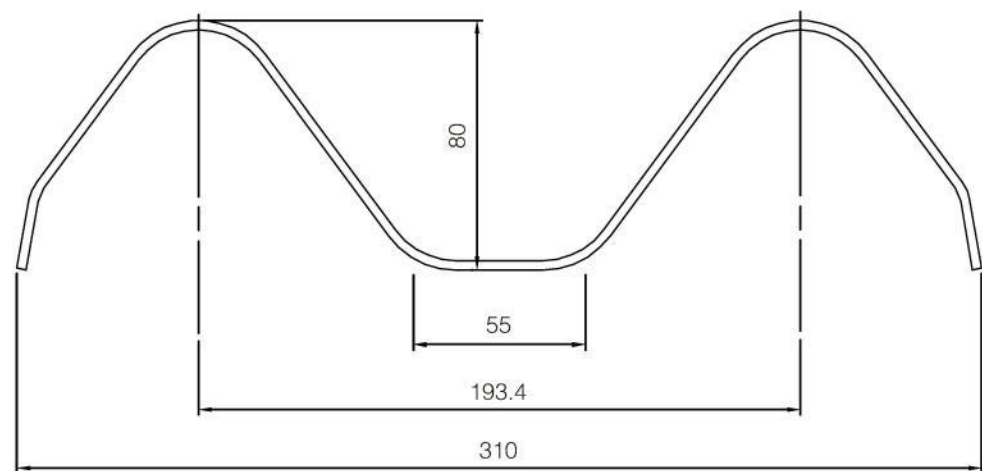

型号 Model	有效覆盖宽度 (mm) Cover width	展开宽度 (mm) Coil width	板厚 (mm) Thickness	用途 Usage
LHA310	310	468	3	公路护栏板 Guard Rail

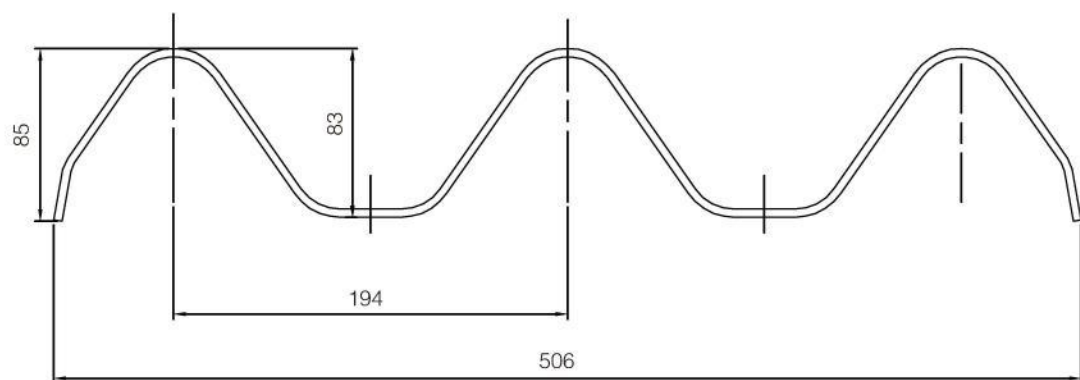

型号 Model	有效覆盖宽度 (mm) Cover width	展开宽度 (mm) Coil width	板厚 (mm) Thickness	用途 Usage
LHA506	506	748	4	公路护栏板 Guard Rail

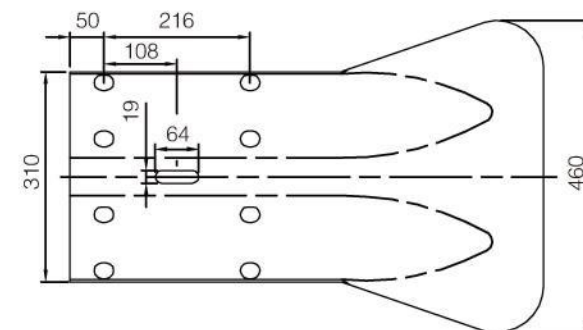
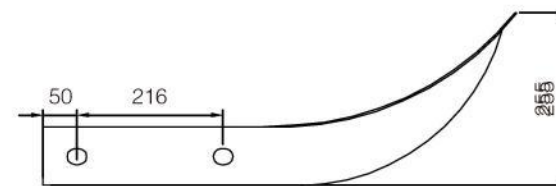

TYPE-A

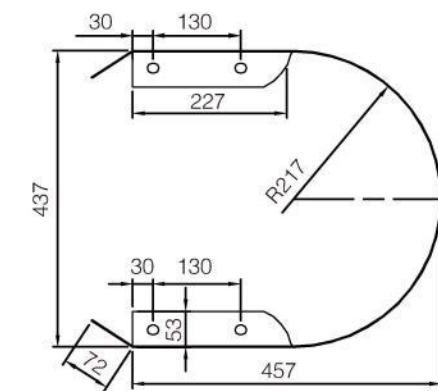

A—A
2:1

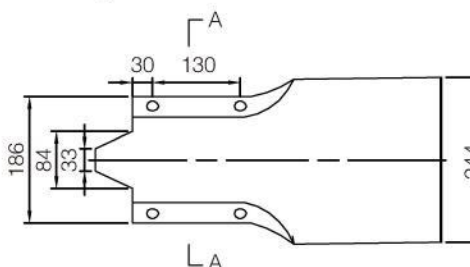
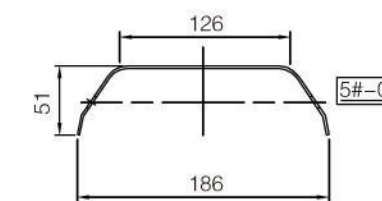

TYPE-B

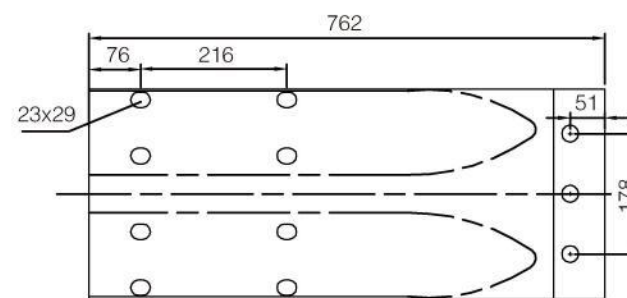

TYPE-C

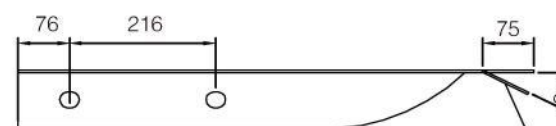

展开图 Layout Drawings

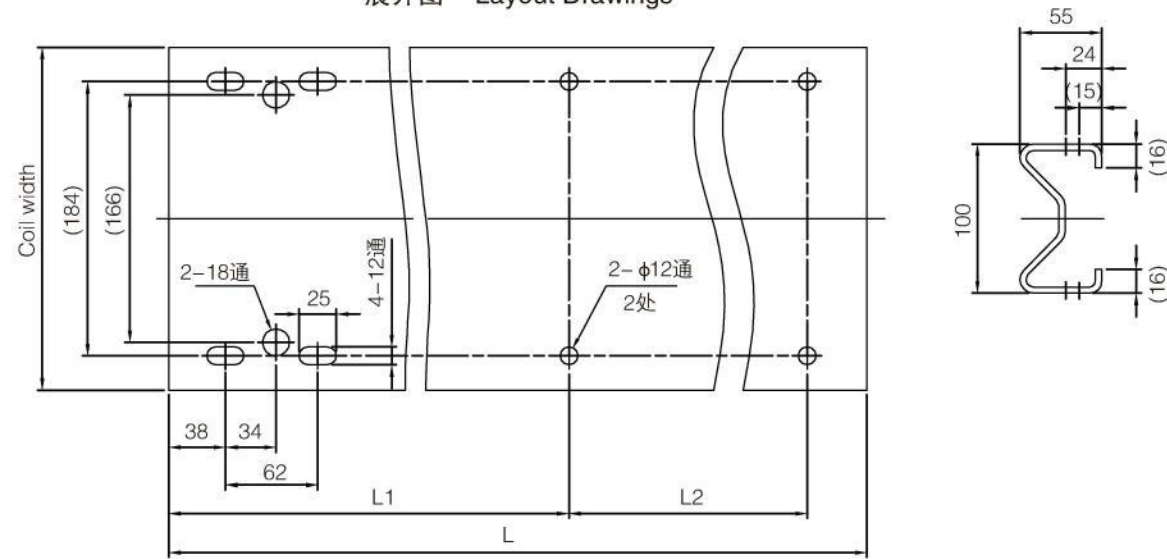

型号 Model	有效覆盖宽度 (mm) Cover width	展开宽度 (mm) Coil width	板厚 (mm) Thickness	用途 Usage
LMA100	100	230	4.0-5.0	护栏板立柱 Guardrail Column

展开图 Layout Drawings

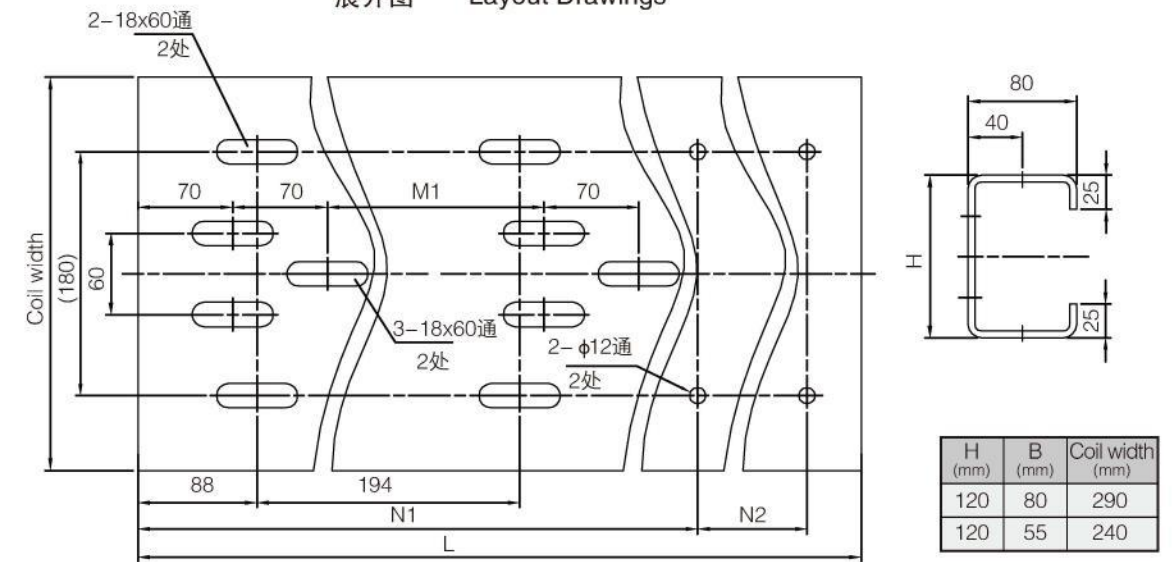

H (mm)	B (mm)	Coil width (mm)
120	80	290
120	55	240

型号 Model	有效覆盖宽度 (mm) Cover width	展开宽度 (mm) Coil width	板厚 (mm) Thickness	用途 Usage
LCA120	120	240/290	4.0-5.0	护栏板立柱 Guardrail Column

展开图 Layout Drawings

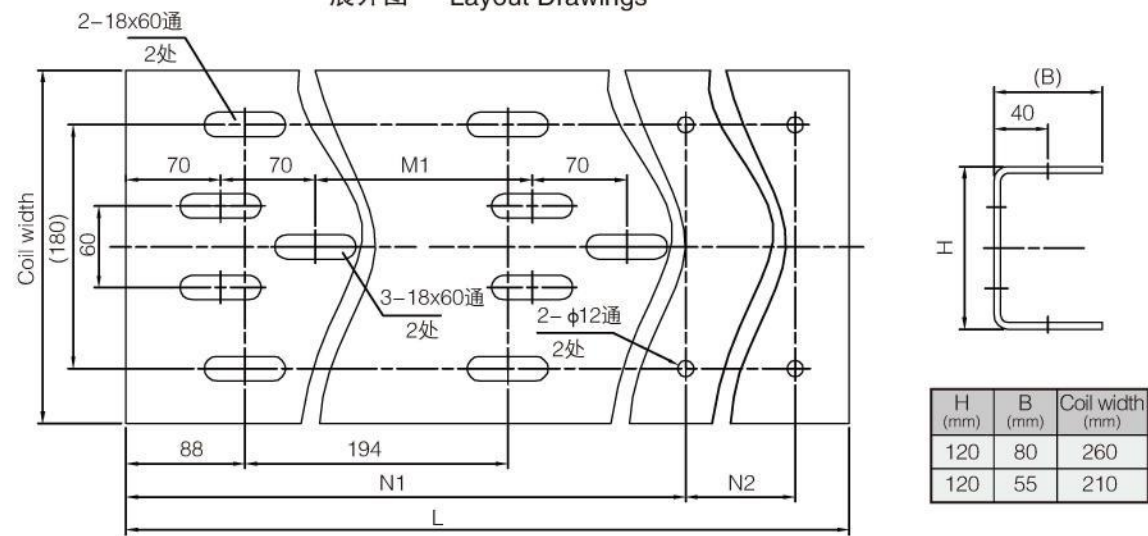

H (mm)	B (mm)	Coil width (mm)
120	80	260
120	55	210

型号 Model	有效覆盖宽度 (mm) Cover width	展开宽度 (mm) Coil width	板厚 (mm) Thickness	用途 Usage
LUA120	120	210/260	4.0-5.0	护栏板立柱 Guardrail Column

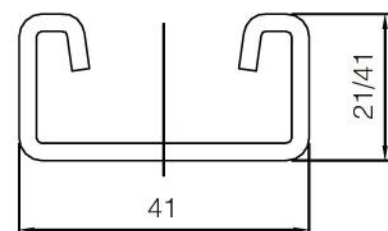
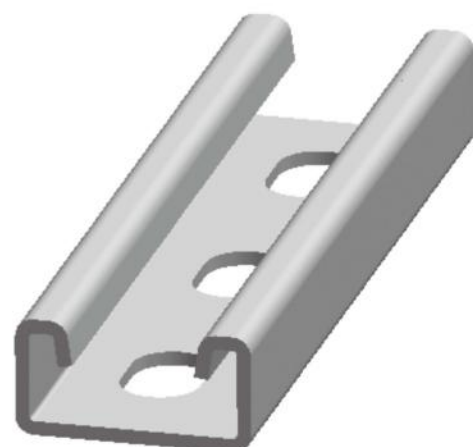

型号 Model	有效覆盖宽度 (mm) Cover width	展开宽度 (mm) Coil width	板厚 (mm) Thickness
LCA41	41	96/136	2 2.5

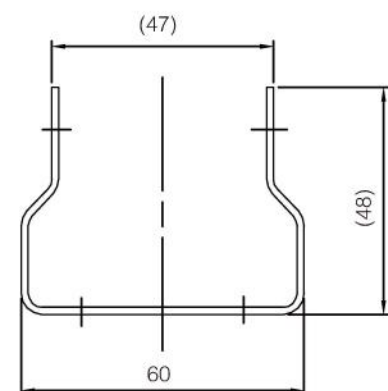
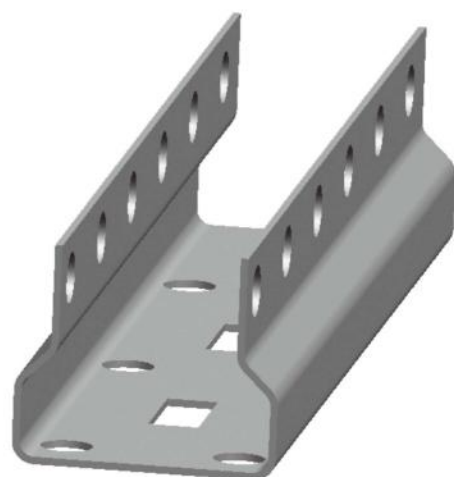

型号 Model	有效覆盖宽度 (mm) Cover width	展开宽度 (mm) Coil width	板厚 (mm) Thickness
LUA60	60	152	1.5

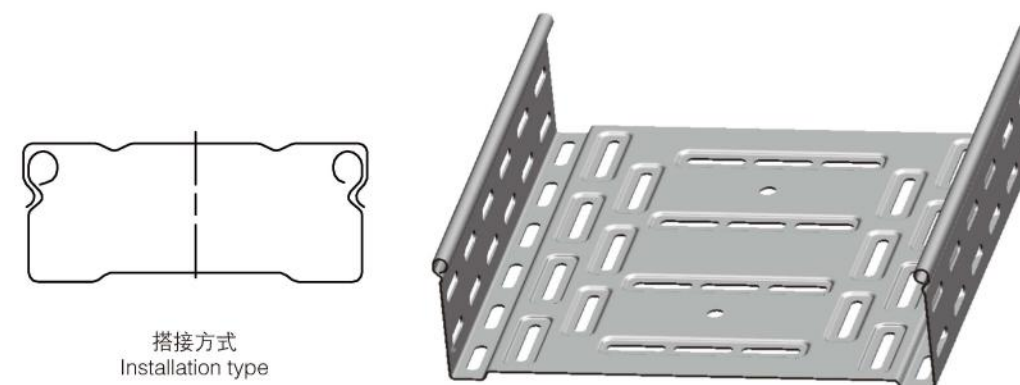
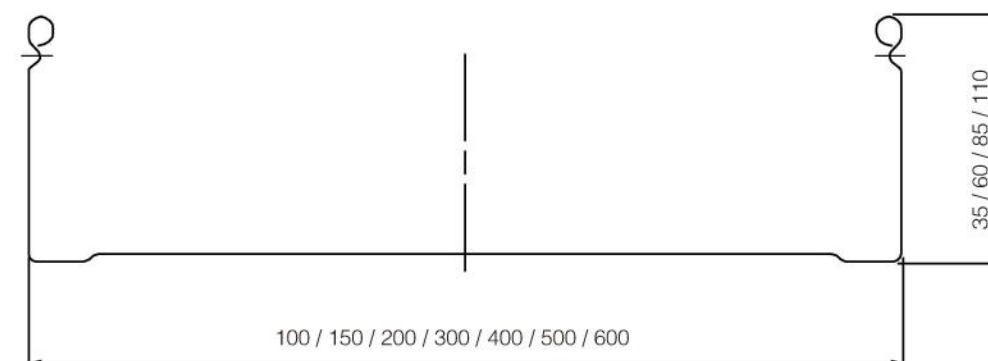

型号 Model	有效覆盖宽度 (mm) Cover width	展开宽度 (mm) Coil width	板厚 (mm) Thickness	用途 Usage
YKA600	100~600	198~848	1.0 1.2	走线槽 Cable trough

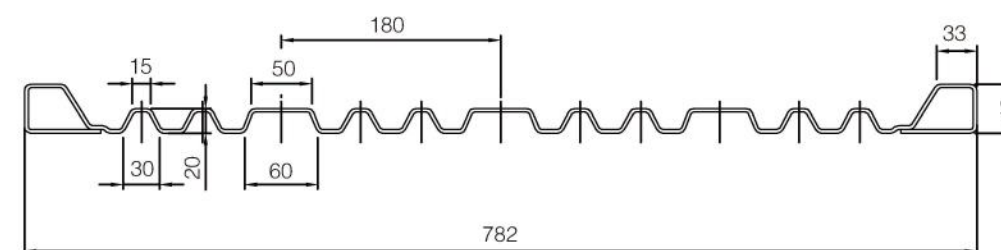

型号 Model	有效覆盖宽度 (mm) Cover width	展开宽度 (mm) Coil width	板厚 (mm) Thickness	用途 Usage
LCA782	782	1200	2.0 3.0	集装箱板 Container Panel

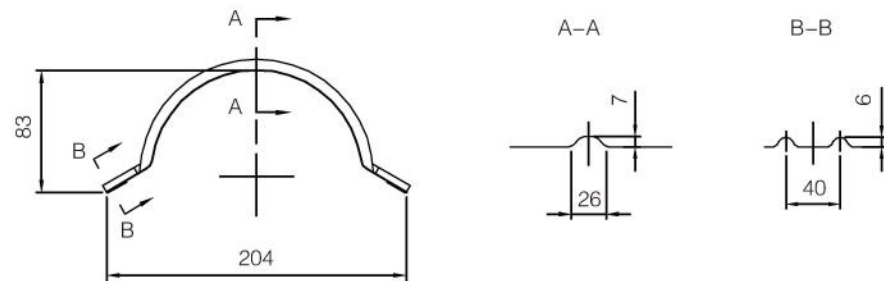
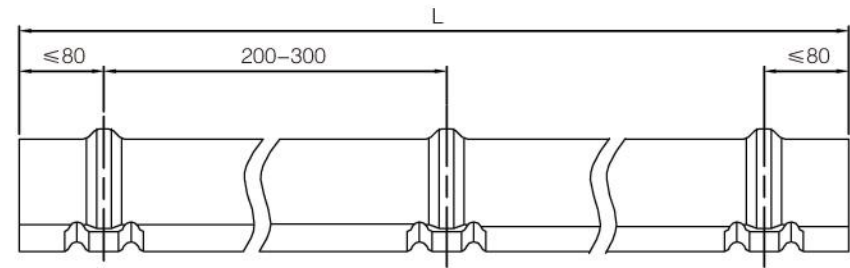

型号 Model	有效覆盖宽度 (mm) Cover width	展开宽度 (mm) Coil width	板厚 (mm) Thickness
YKA204	204	312	0.4
			0.6

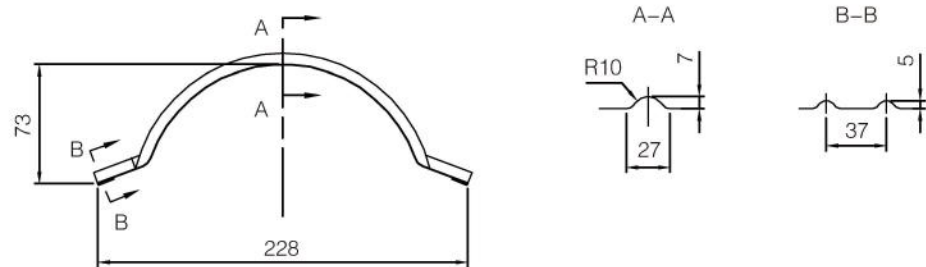
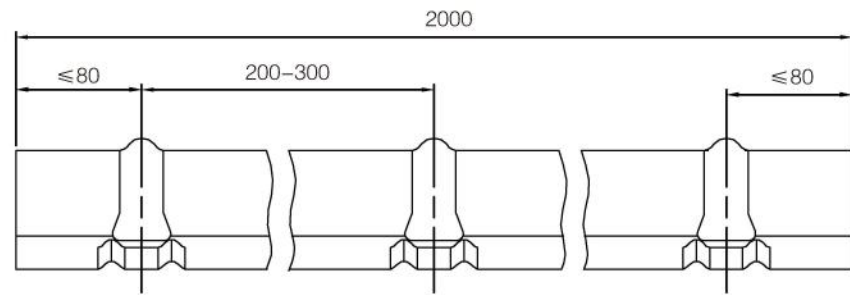

型号 Model	有效覆盖宽度 (mm) Cover width	展开宽度 (mm) Coil width	板厚 (mm) Thickness
YKA228	228	305	0.4
			0.8

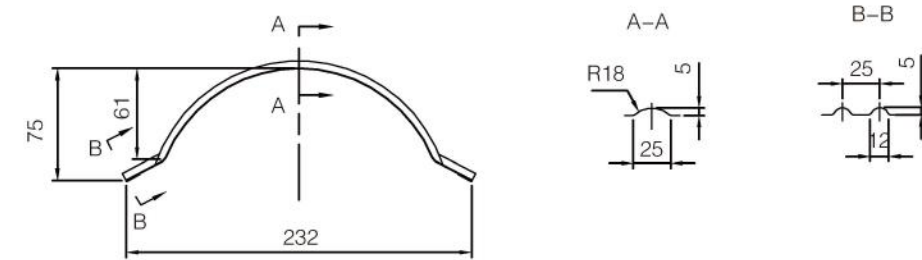
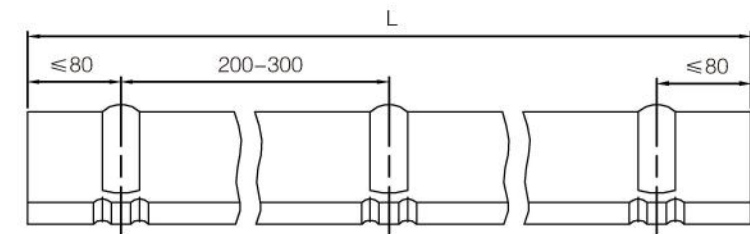

型号 Model	有效覆盖宽度 (mm) Cover width	展开宽度 (mm) Coil width	板厚 (mm) Thickness
YKA232	232	310	0.4
			0.8

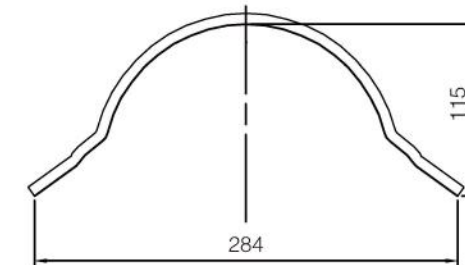
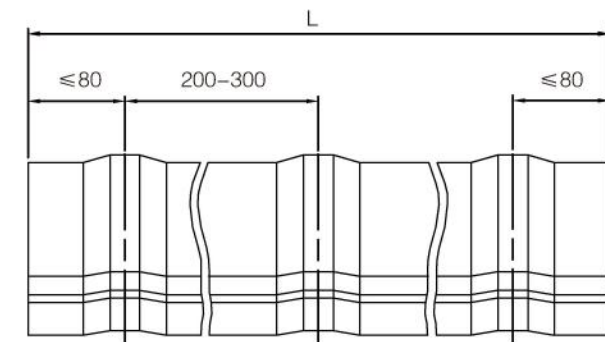

型号 Model	有效覆盖宽度 (mm) Cover width	展开宽度 (mm) Coil width	板厚 (mm) Thickness
YKA284	284	385	0.5
			0.6

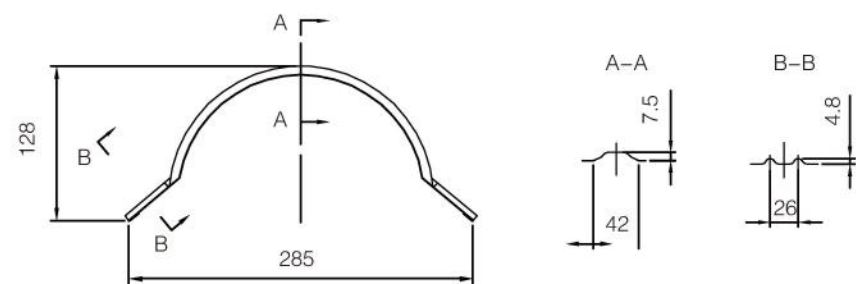
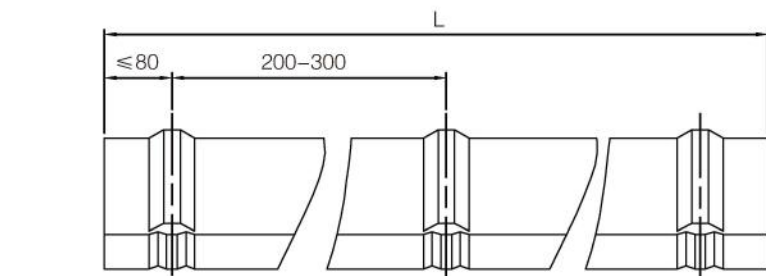

型号 Model	有效覆盖宽度 (mm) Cover width	展开宽度 (mm) Coil width	板厚 (mm) Thickness
YKA285	285	420	0.5 0.55

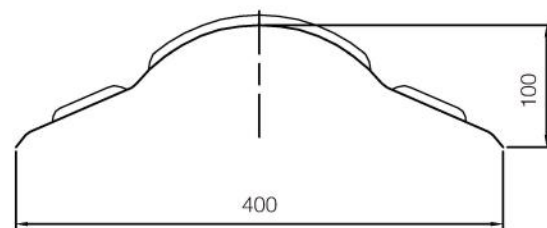
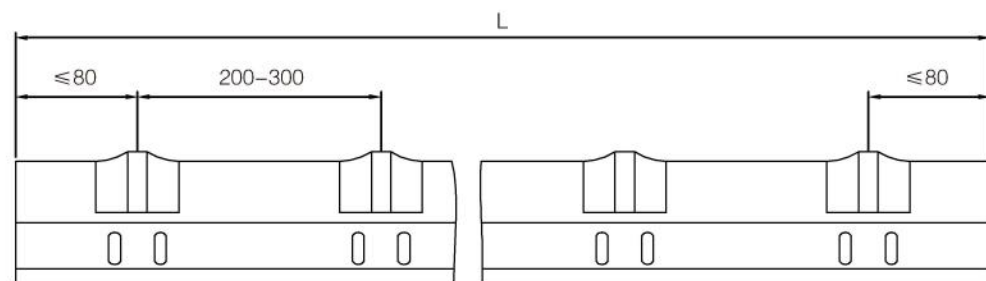

型号 Model	有效覆盖宽度 (mm) Cover width	展开宽度 (mm) Coil width	板厚 (mm) Thickness
YKA400	400	457	0.4 0.6

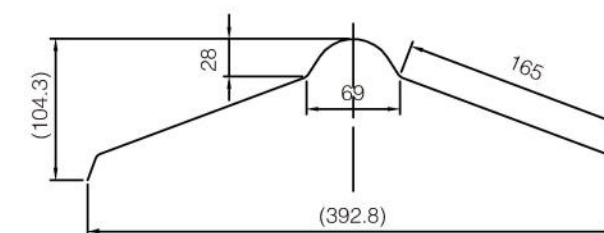
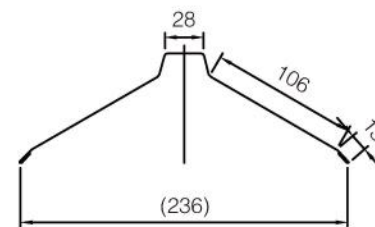

型号 Model	展开宽度 (mm) Coil width	板厚 (mm) Thickness
YKA232	312	0.35-0.6

型号 Model	展开宽度 (mm) Coil width	板厚 (mm) Thickness
YKA165	460	0.5-0.6

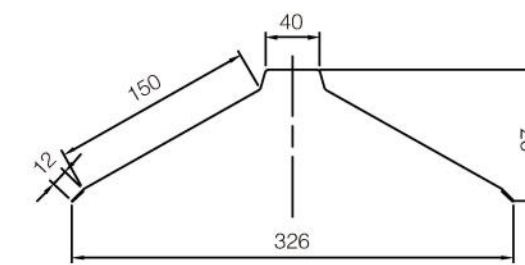
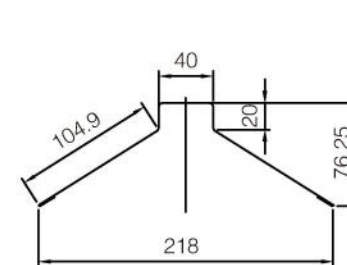

型号 Model	展开宽度 (mm) Coil width	板厚 (mm) Thickness
YKA218	312	0.35-0.6

型号 Model	展开宽度 (mm) Coil width	板厚 (mm) Thickness
YKA326	410	0.5-0.55

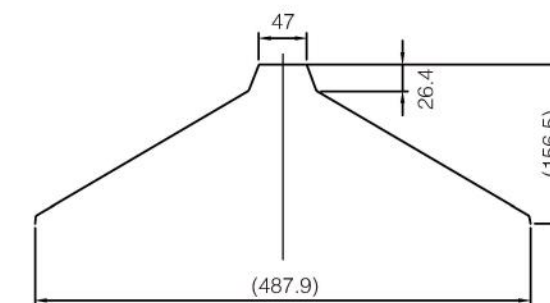
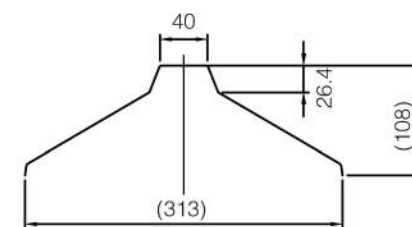

型号 Model	有效覆盖宽度 (mm) Cover width	展开宽度 (mm) Coil width	板厚 (mm) Thickness
YKA487	313/487	400/600	0.3 0.5

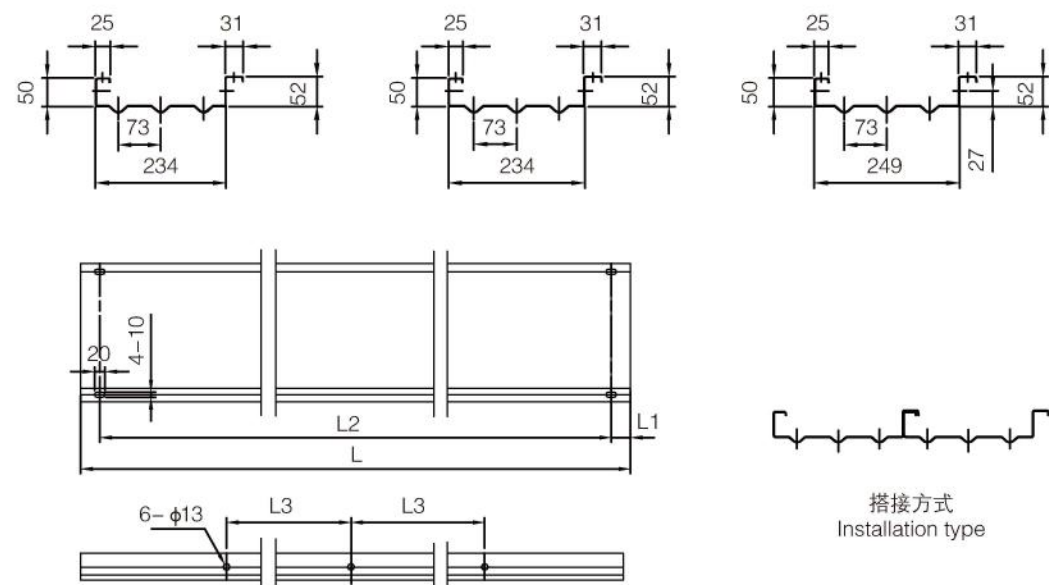

型号 Model	有效覆盖宽度 (mm) Cover width	展开宽度 (mm) Coil width	板厚 (mm) Thickness
LCA249	224/234/249	390/400/415	2.0
			2.3

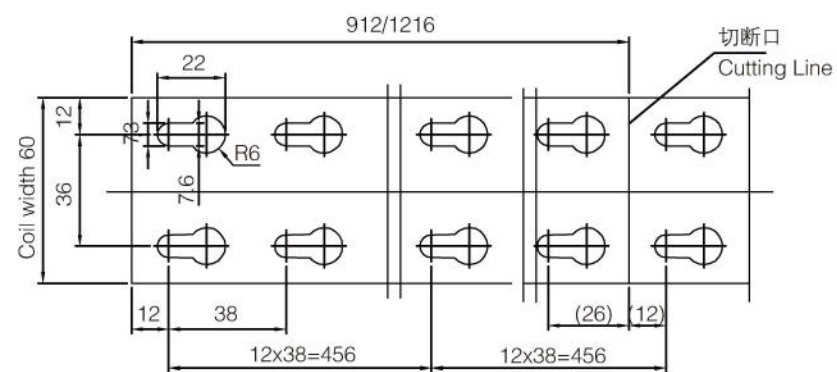
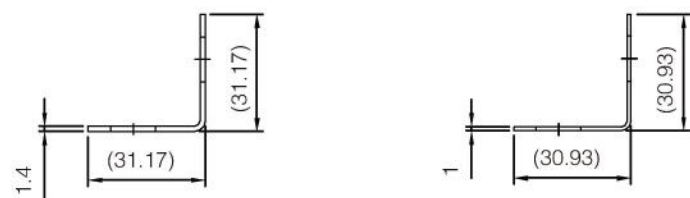

型号 Model	有效覆盖宽度 (mm) Cover width	展开宽度 (mm) Coil width	板厚 (mm) Thickness
YKA31	31	60	1.0
			1.4

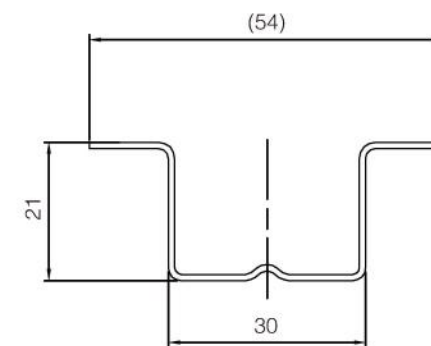

型号 Model	展开宽度 (mm) Coil width	板厚 (mm) Thickness
YKA30	90	0.8-0.95

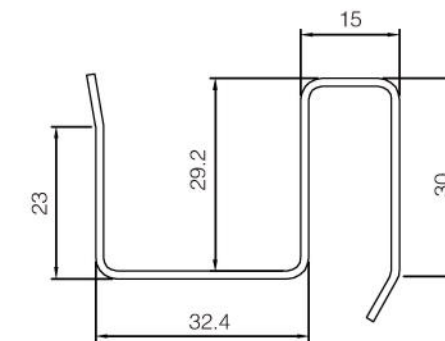

型号 Model	展开宽度 (mm) Coil width	板厚 (mm) Thickness
YKA32	135	1.2

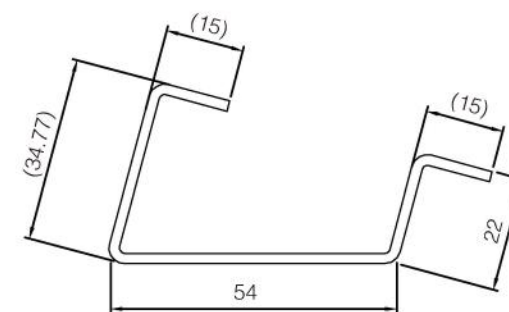

型号 Model	展开宽度 (mm) Coil width	板厚 (mm) Thickness
YKC54A	129	1.5-2.25

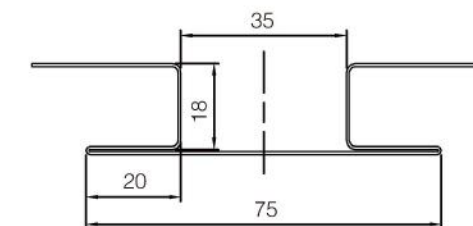

型号 Model	展开宽度 (mm) Coil width	板厚 (mm) Thickness
YKA75	208	0.4-0.6

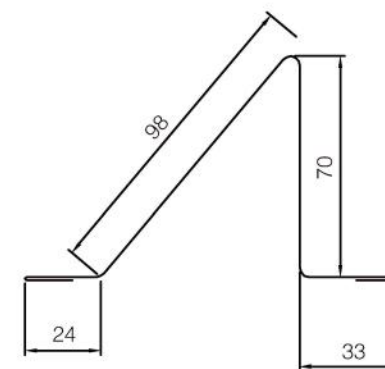

型号 Model	展开宽度 (mm) Coil width	板厚 (mm) Thickness
YKA98	250	0.35-0.6

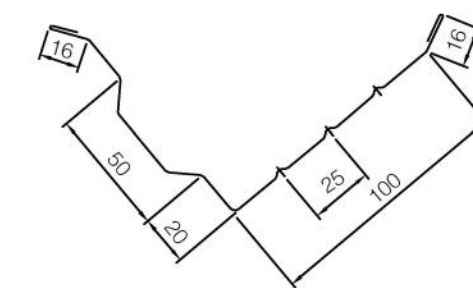

型号 Model	展开宽度 (mm) Coil width	板厚 (mm) Thickness
YKC100	250	0.35-0.6

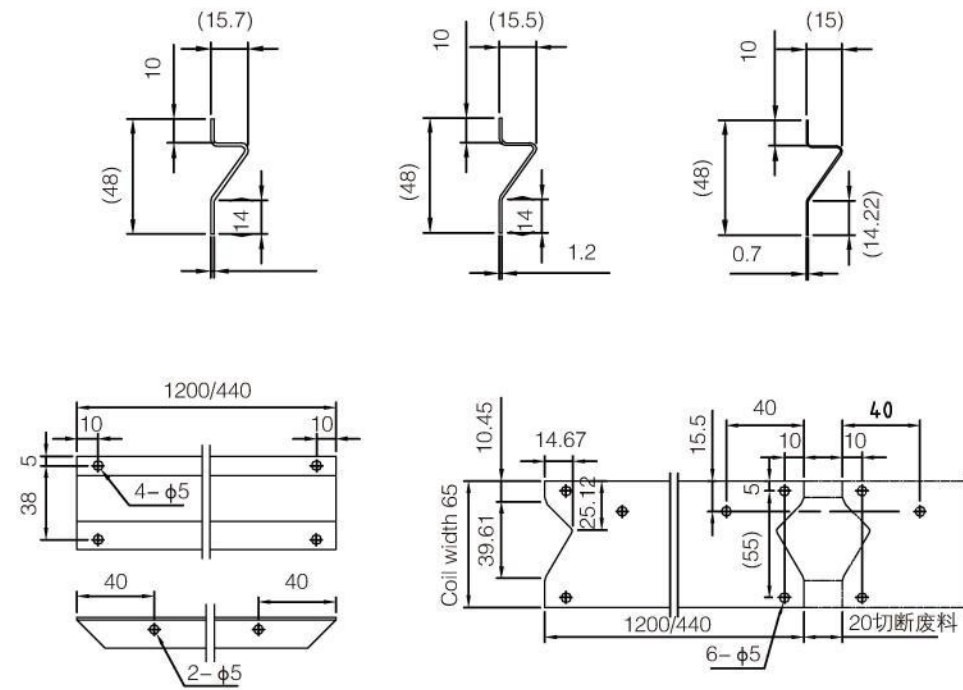

型号 Model	有效覆盖宽度 (mm) Cover width	展开宽度 (mm) Coil width	板厚 (mm) Thickness
YKA48	48	65	0.7
			1.4

A向 底面压花图
Embossing drawings

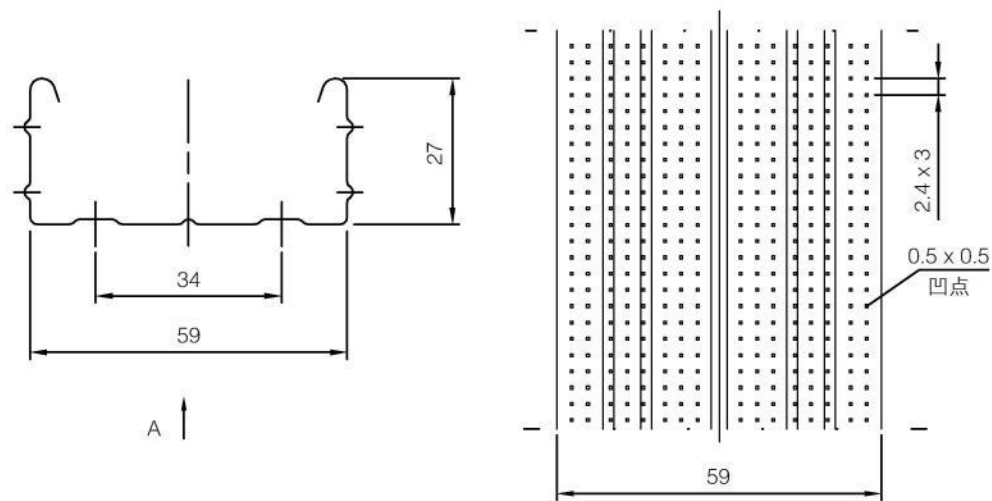

型号 Model	有效覆盖宽度 (mm) Cover width	展开宽度 (mm) Coil width	板厚 (mm) Thickness
YKC60	60	127	0.5

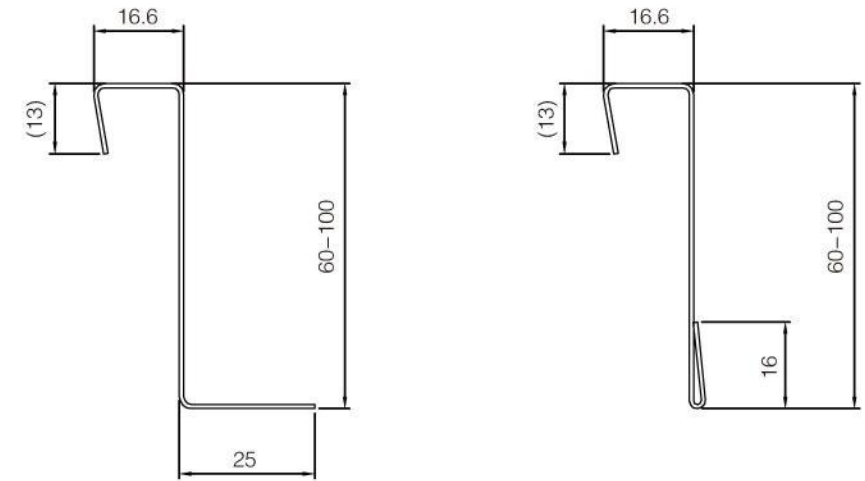

型号 Model	有效覆盖宽度 (mm) Cover width	展开宽度 (mm) Coil width	板厚 (mm) Thickness
YKA100	60-100	102-148	0.5
			0.8

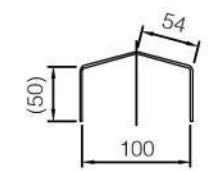

Coil width 201mm

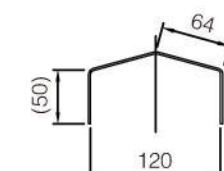

Coil width 222mm

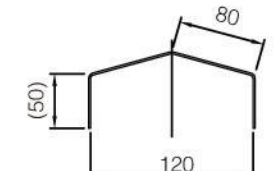

Coil width 253mm

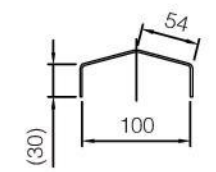

Coil width 161mm

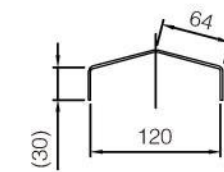

Coil width 182mm

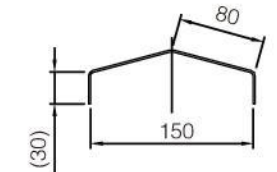

Coil width 213mm

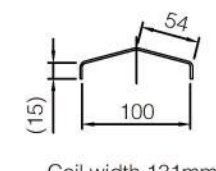

Coil width 131mm

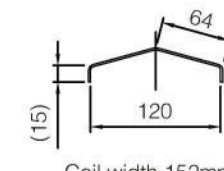

Coil width 152mm

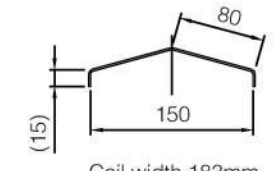

Coil width 183mm

型号 Model	有效覆盖宽度 (mm) Cover width	展开宽度 (mm) Coil width	板厚 (mm) Thickness
YKA150	100-150	131-253	1.5-2.25

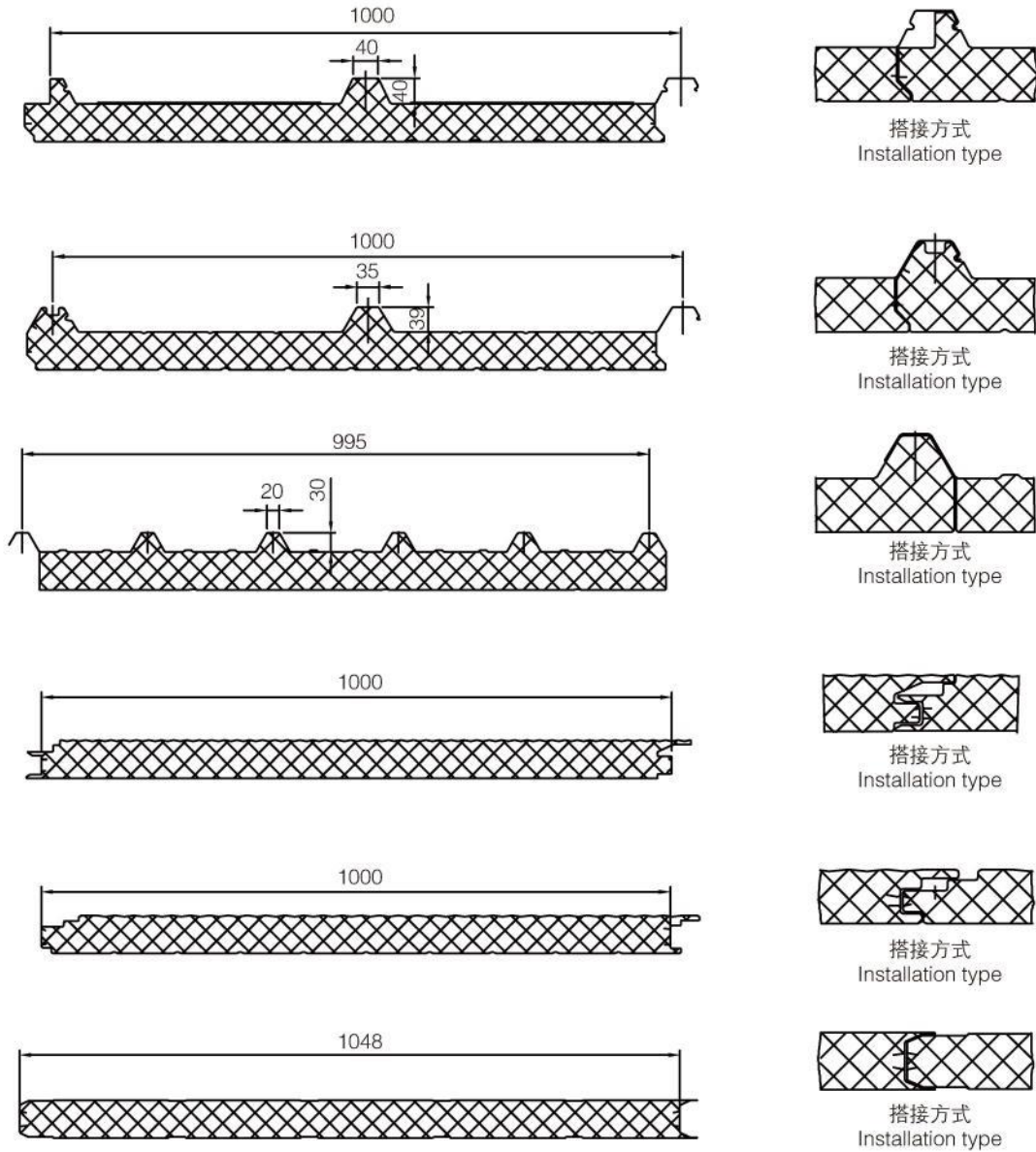

机型 Model	名称 Name	有效覆盖宽度 (mm) Cover width	展开宽度 (mm) Coil width	用途 Usage
SMT-PU100	瓦楞式PU芯复合板 Corrugation Type PU Sandwich Panel	1000	1250 / 1070	屋面板 Roof
	瓦楞式PU芯复合板 Corrugation Type PU Sandwich Panel	1000	1200 / 1070	屋面板 Roof
	瓦楞式PU芯复合板 Corrugation Type PU Sandwich Panel	995	1220 / 1020	屋面板 Roof
	插入式PU芯复合板 Corrugation Type PU Sandwich Panel	1000	1200 / 1070	墙面板 Wall
	插入式PU芯复合板 Corrugation Type PU Sandwich Panel	1000	1140 / 1070	墙面板 Wall
	插入式PU芯复合板 Corrugation Type PU Sandwich Panel	1048	1145 / 1145	墙面板 Wall

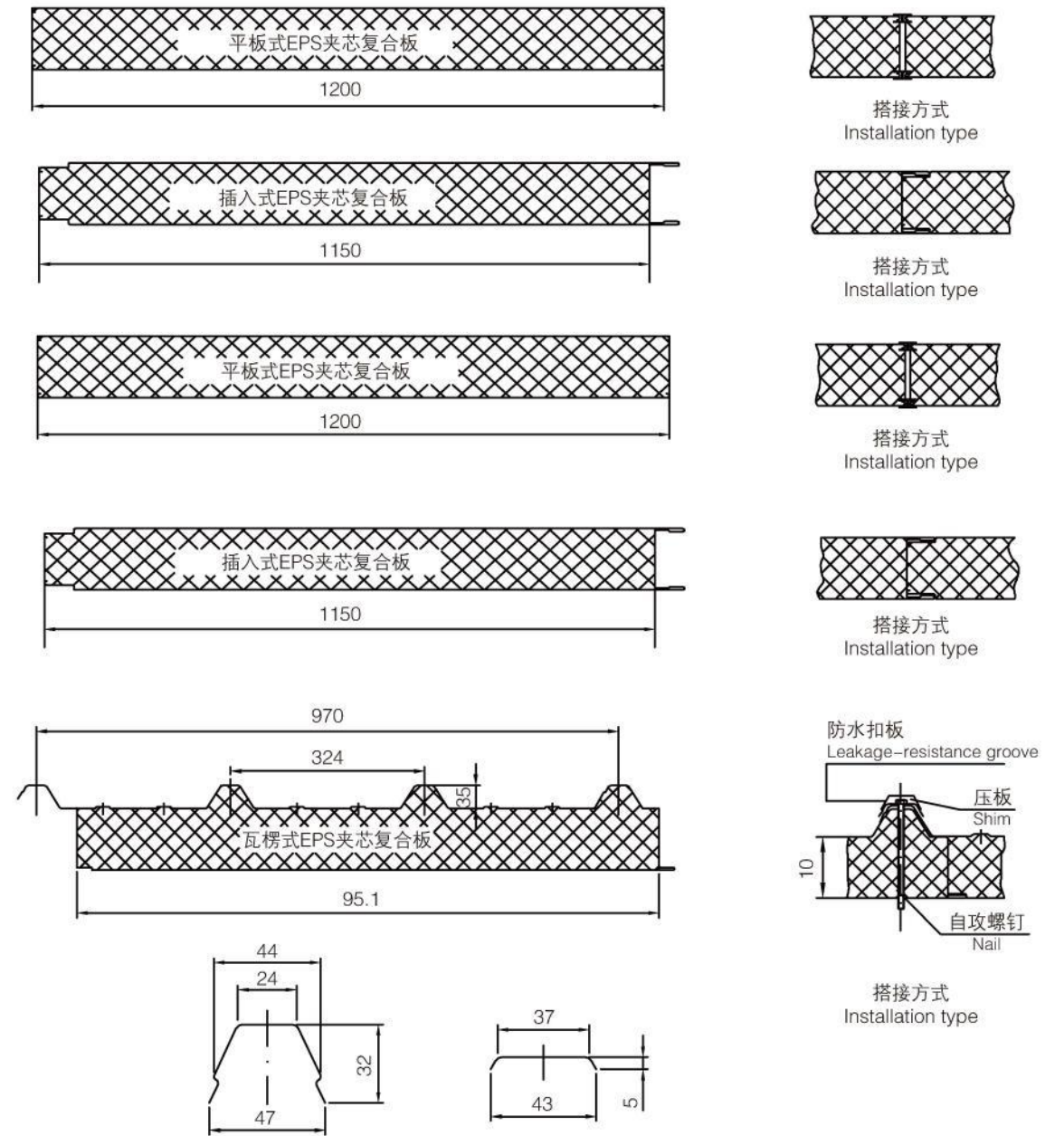

机型 Model	名称 Name	有效覆盖宽度 (mm) Cover width	展开宽度 (mm) Coil width	用途 Usage
SMT-II	平板式EPS夹芯复合板 Apron Type EPS Sandwich Panel	1200	1200	屋面板 Roof
	插入式EPS夹芯复合板 Push-in Type EPS Sandwich Panel	1150	1200	墙面板 Wall
SMT-III	平板式EPS夹芯复合板 Apron Type EPS Sandwich Panel	1200	1200	屋面板 Roof
	插入式EPS夹芯复合板 Push-in Type EPS Sandwich Panel	1150	1200	墙面板 Wall
	瓦楞式EPS夹芯复合板 Corrugation Type EPS Sandwich Panel	970	1200 / 1000	屋面板 Roof

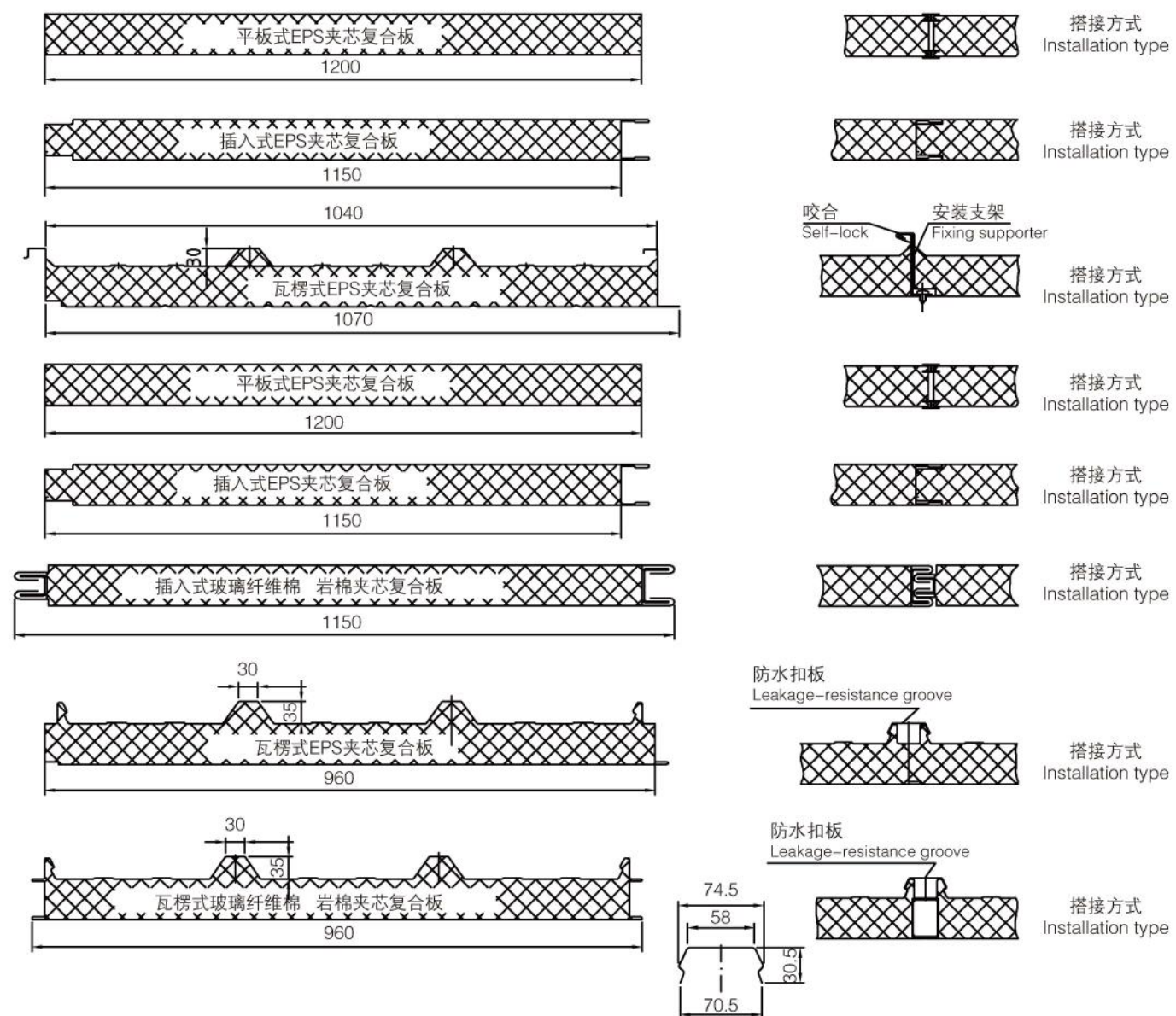

ALL PUBLISHING RIGHTS RESERVED BY
 SHAOXING COUNTY SMARTECH MACHINERY MANUFACTURING CO., LTD.

机型 Model	名称 Name	有效覆盖宽度 (mm) Cover width	展开宽度 (mm) Coil width	用途 Usage
SMT-IV	平板式EPS夹芯复合板 Apron Type EPS Sandwich Panel	1200	1200	屋面板 Roof 墙面板 Wall
	插入式EPS夹芯复合板 Push-in Type EPS Sandwich Panel	1150	1200	墙面板 Wall
	瓦楞式EPS夹芯复合板 Corrugation Type EPS Sandwich Panel	1040	1200/1085	屋面板 Roof
SMT-VII	平板式EPS夹芯复合板 Apron Type EPS Sandwich Panel	1200	1200	屋面板 Roof 墙面板 Wall
	插入式EPS夹芯复合板 Push-in Type EPS Sandwich Panel	1200	1200	墙面板 Wall
	插入式EPS夹芯复合板 Push-in Type EPS Sandwich Panel	1200	1200	墙面板 Wall
	瓦楞式EPS夹芯复合板 Corrugation Type EPS Sandwich Panel	960	1180 / 1000	屋面板 Roof
	瓦楞式EPS夹芯复合板 Corrugation Type EPS Sandwich Panel	960	1200 / 1000	屋面板 Roof